

# McKenzie Occasional Table

## Assembly Instructions

**AFGAC = Glazed Antique Cherry finish**

**AFCAF = Caffè finish**

Model #

**3501AFGAC; 3501AFCAF**

**McKenzie End Table**



Model #

**3504AFGAC; 3504AFCAF**

**McKenzie Coffee Table**

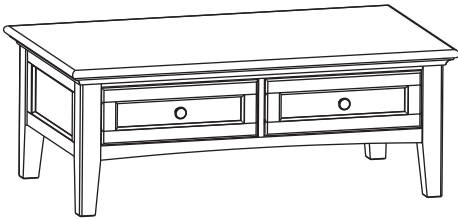

### **Congratulations!**

*This fine piece of furniture will make a gorgeous addition to your home. For the best results, read the Assembly Instructions before you begin your project.*



### **IMPORTANT NOTES:**

- For normal household use only. **Not** recommended for commercial use.
- Unload items before you move this unit.
- Do not overload the drawers.
- Before you load or move this unit, check to make sure all screws and supports are tight.
- Before you begin your project, completely read the Assembly Instructions.
- Store this item: 1- in its box; 2- in a dry place; 3- in temperatures that range from 40°F to 90°F (not on a cold and possibly damp cement floor).
- Periodically inspect your furniture for any loose glue joints, screws or any other problem that might affect the stability of your furniture. Tighten or repair as needed.

**DESIGN SUBJECT TO CHANGE WITHOUT NOTICE.**



**CALL US FIRST!** *Do not return this item to the store.*

**Service Policy:** We will replace any part that is defective, missing or damaged during assembly. For a replacement part, directly contact Whittier Wood Products customer service department by phone, fax, mail or email.

**Hours:** Our friendly customer service staff can be reached Monday-Friday 7:00 a.m. to 5:00 p.m. (Pacific Time). You may leave a message 24 hours a day, seven days a week.

**To Order:** Provide the furniture model number (found above the illustration of your unit), the part letter, production code, quantity needed, reason for replacement, your full name, address and telephone number.

*Parts ship from our Eugene, Oregon factory within one or two business days from the time we receive your request. Please allow five to ten business days for delivery.*

**800-653-3336** • Outside the U.S. or Canada: 541-687-0213 • Fax: 541-687-2060  
www.whittierwood.com • P.O. Box 2827 • Eugene, Oregon 97402, U.S.A.

**Whittier  
Wood**  
FURNITURE

P.O. Box 2827  
Eugene, OR 97402 USA

Production Code:











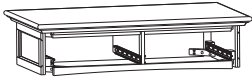

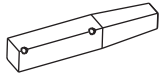
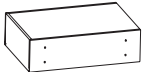

VN

08/25/10

# 3501AFGAC; 3504AFGAC 3501AFCAF; 3504AFCAF

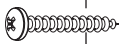
## McKenzie Occasional Table — Parts List

Please identify the parts and check that quantities received match those on this list.  
If you need to replace a part, refer to the following letter and model name.

Part	Description	Quantity	
		3501AFGAC 3501AFCAF	3504AFGAC 3504AFCAF
A	Case 	1	1
B	Top Assembly (attached) 	1	1
C	Leg 	4	4
E	Drawer (inserted) 	2	2
F	Drawer Face (installed) 	2	2
G	20" Drawer Slides (installed) 	2 sets	2 sets
H	#6 x 3/4" Philtruss Screw (inserted) 	12	12
I	#6 x 1/2" Philtruss Screw (inserted) 	12	12
J	Knob (attached) 	2	2
K	#8 x 1-1/2" Machine Screw (installed) 	2	2
L	T-Nut (inserted) 	4	4
M	Adjustable Glide (inserted) 	4	4
N	#8x1-1/4" Pan Head Screw (inserted) 	42	77
O	#8 x 7/8" LoProfile Screw (inserted) 	8	8
P	Insert Nut (inserted) 	8	8
Q	5/16" Flat Washer 	8	8
R	3/8" x 2-1/2" Hex Bolt 	8	8

3504 shown in illustrations.

# 3501AFGAC, 3504AFGAC 3501AFCAF, 3504AFCAF McKenzie Occasional Table Assembly Instructions

Tools Required: 9/16" or Adjustable Wrench

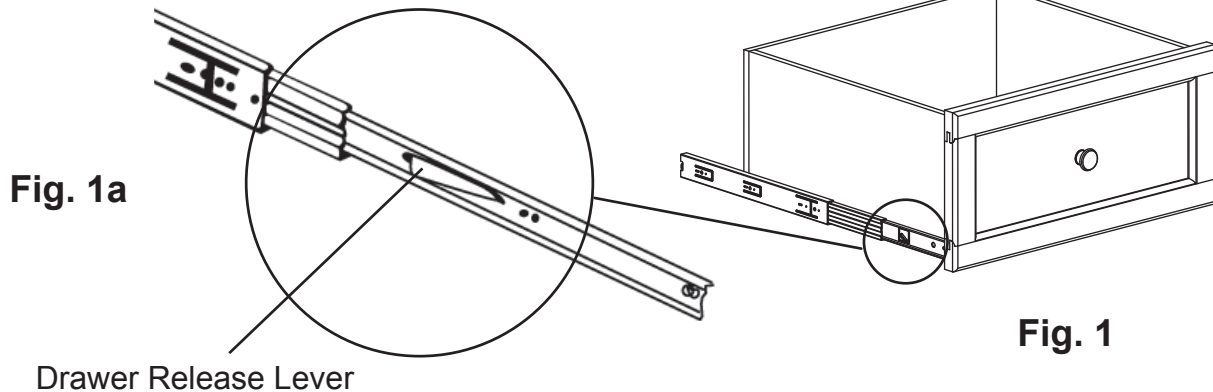

1. Remove the Drawers (E) from the Case (A). To remove the drawers, pull up on the left side of the Drawer Release Lever while pushing down on the right Drawer Release Lever. See Figure 1a. Note where each drawer came from to ensure correct installation. Positions are marked on the drawer bottoms.

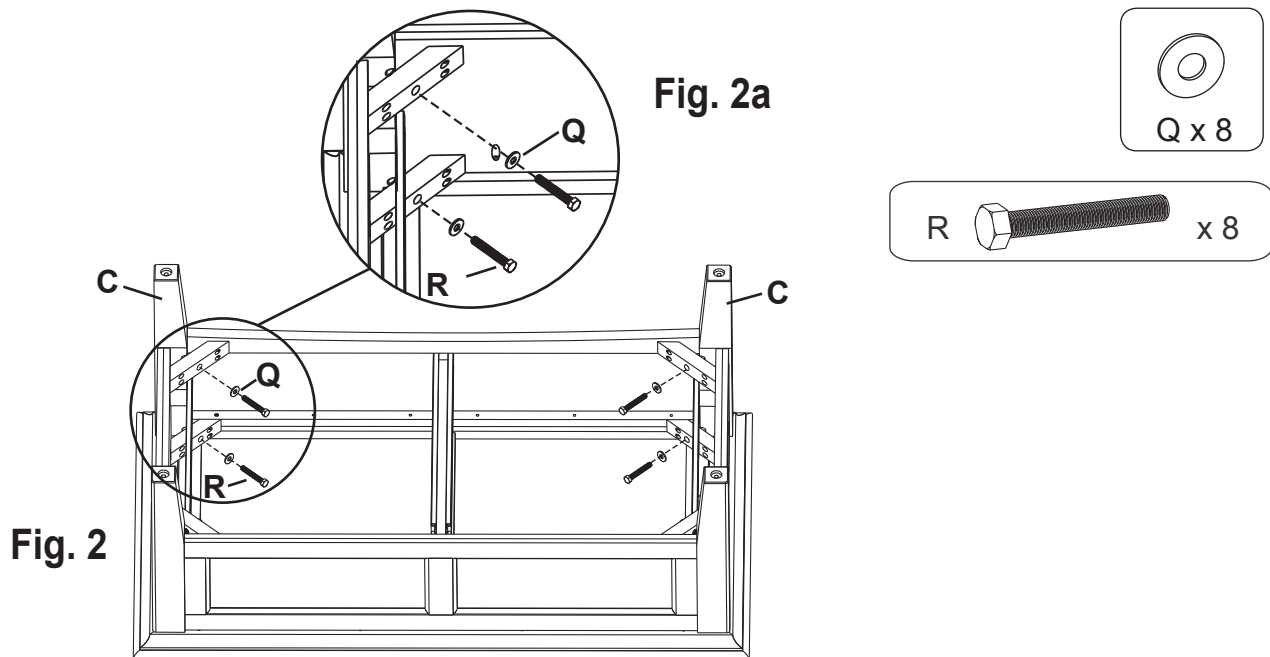

2. Turn the unit upside down on a clean, protected surface. Place two Legs (C) at the front corners of the Case, making sure the drilled corners of the legs face toward the Corner Blocks. Insert two 3/8" x 2-1/2" Hex Bolts (R) with two 5/8" Flat Washers (Q) through the Corner Blocks and into the leg and fasten securely. See Figures 2 and 2a. Repeat for the other two legs.

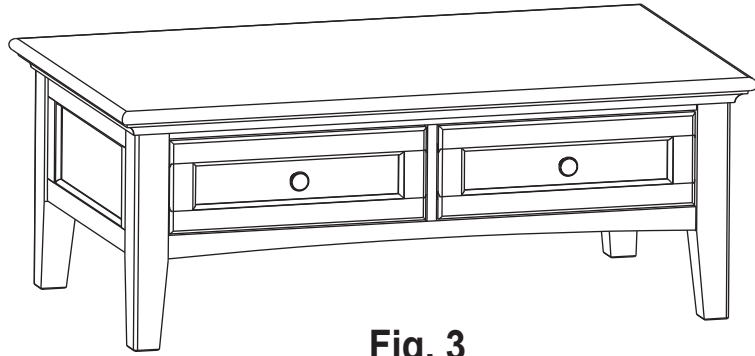

**Fig. 3**

3. Turn the table upright and insert the Drawers (E).

---

4. Place the table at its final destination. To level the table, rotate the Adjustable Glide (M) found at the bottom of each leg.