

Model #

2906AUF

48" Pedestal Extension Table

Assembly Instructions

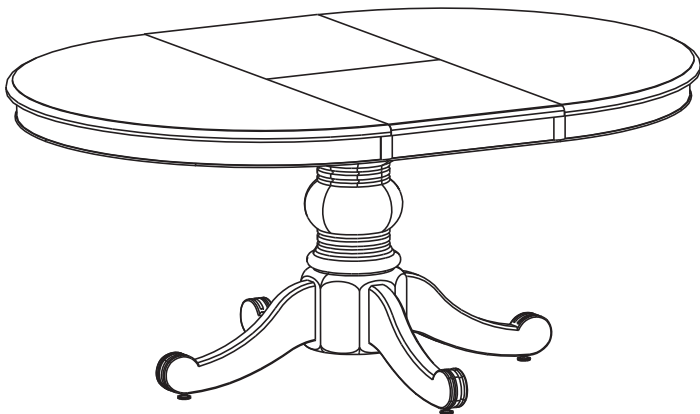

Congratulations!

This fine piece of furniture will make a gorgeous addition to your home. For the best results, read both the Assembly Instructions and Finishing Hints before you begin your project.

**For normal household use only.
NOT recommended for commercial use.**



Do not climb, sit or stand on this piece of furniture.

DESIGN SUBJECT TO CHANGE WITHOUT NOTICE.

**Whittier
Wood**™
FURNITURE

P.O. Box 2827
Eugene, OR 97402 USA



CALL US FIRST!
DO NOT RETURN ITEM TO STORE

Service Policy: We will replace any part that is defective, missing or damaged during assembly. Please directly contact Whittier Wood Products customer service department (by phone, fax, mail or email) for a replacement part.

Hours: Our friendly customer service staff can be reached Monday-Friday 7:00 a.m. to 5:00 p.m. (Pacific Time). Or you may leave a message 24 hours a day, 7 days a week.

To Order: Provide the complete furniture model number (upper left corner of this page), the part letter, production code, quantity needed, the reason for replacement and your full name and address along with a telephone number in case we need to contact you.

Parts ship from our Eugene, Oregon factory within one or two business days from the time we receive your request. Please allow five to ten business days for delivery.

800-653-3336

Outside U.S. or Canada: 541-687-0213

Fax: 541-687-2060 • www.whittierwood.com

Mail: P.O. Box 2827 • Eugene, Oregon 97402, U.S.A.

IMPORTANT NOTES:

- Before you begin your project, completely read the Assembly Instructions and Finishing Hints.
- Store the parts: 1~ in their box; 2~ in a dry place; 3~ in temperatures that range from 40° to 90° F (not on a cold and possibly damp cement floor).
- Inspect your furniture periodically for any loose glue joints, screws or any other problem that might affect the stability of your furniture. Tighten or repair as needed.
- This assembly requires two people.

Production Code:

VN

10/09

2906AUF 48" Pedestal Extension Table — Parts List

Before beginning assembly, check that the quantities of parts received match those listed below.
If you need to replace a part, please refer to the following list for name and number.

2907AUF

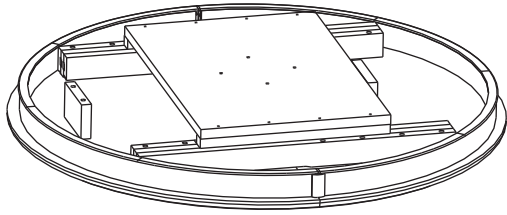

A — Top Assembly
— Qty. 1

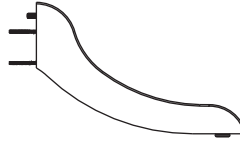

C — Foot — Qty. 4

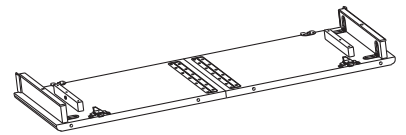

G — Leaf Assembly — Qty. 1

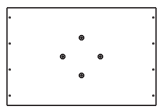

H — Top Support
(attached) — Qty. 1

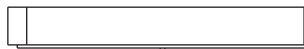

I — Leaf Apron
(attached) — Qty. 2



J — Block #1
(attached) — Qty. 1



X — Block #2
(attached) — Qty. 1

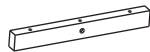

K — Apron Cleat
(attached) — Qty. 2



Y — Top Support Cleat
(attached) — Qty. 2

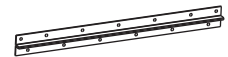

ZE — Bracket
(attached) — Qty. 2

PART ITEM	DESCRIPTION	QUANTITY
D	5/16"x3" Lag Bolt	4
E	5/16" Flat Washer	12
F	3/8" Hex Nut	8
L	#8 x 1 3/4" Pan Head Screw (inserted) ..	40
MA	Apron Hinge (attached)	4
MB	Leaf Hinge (attached)	3
N	Lever Lock (attached)	4
O	Leveler Plate (attached)	4
ZH	#8 x 5/8" Flat Head Screw (inserted) ..	40
Q	3/8"x4 1/2" Hanger Bolt (inserted)	8
R	Insert Nut (inserted)	4
S	Adjustable Glide (attached)	4
T	3/8" Guide Pin (inserted)	8

PART ITEM	DESCRIPTION	QUANTITY
U	1/2" x 2 1/4" Wood Dowel (inserted)	4
V	Slide (installed)	2 sets
VA	#10x1"Oval Head Screw (inserted) ..	2
VB	420mmToothed slide (attached)	2 sets
VC	Rafix Pin (attached)	4
W	#12 x 1 3/4" Pan Head Screw (inserted) ..	16
ZA	Apron Cap (attached)	4
ZB	90° Bracket (attached)	4
ZC	#6 x 5/16" Flat Head Screw (inserted) ..	8
ZD	#6 x 3/4" Brass Flat Head Screw (inserted)	24
ZF	#8 x 1-3/16" Flat Head Screw (inserted) ..	12
ZG	#6 x 5/8" Philtruss Screw (inserted)	26
ZI	Brass Pin (inserted)	2 sets

2908AUF

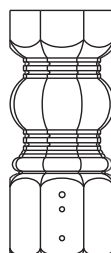

B — Pedestal
— Qty.1

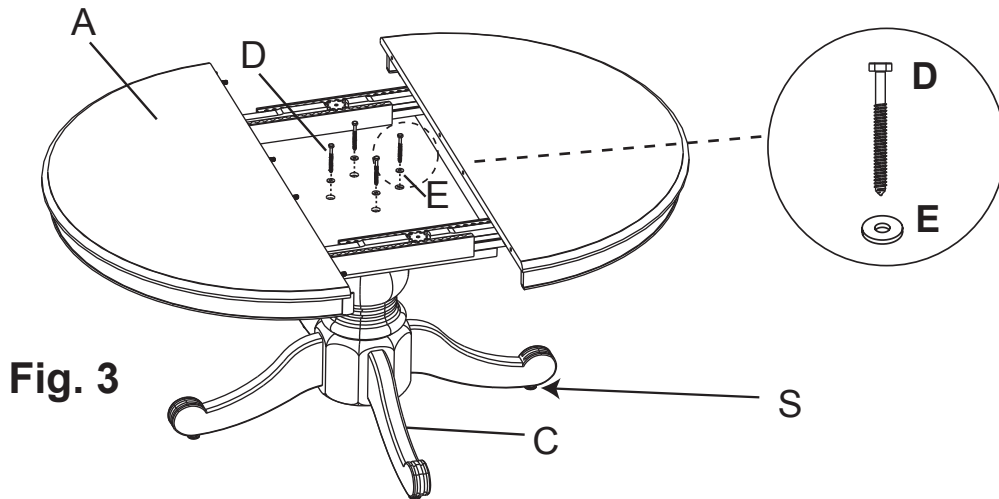

Fig. 3a

3. Turn the Pedestal right-side up and line up the pre-drilled holes in the Top Assembly to the pre-drilled holes in the pedestal. Attach using four 5/16"x3" Lag Bolts (D) and four 5/16" Washers (E) as shown in Figures 3 and 3a. To level the table, turn the Adjustable Glides (S) on the bottom of each Foot (C).

Fig. 4

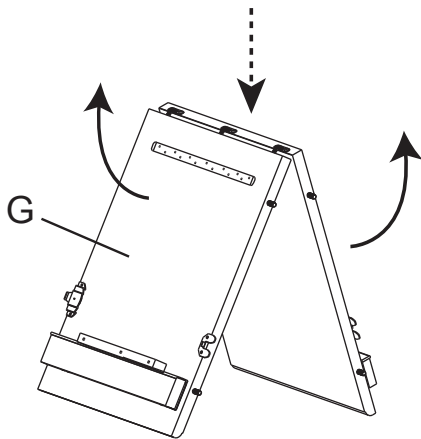

Fig. 4a

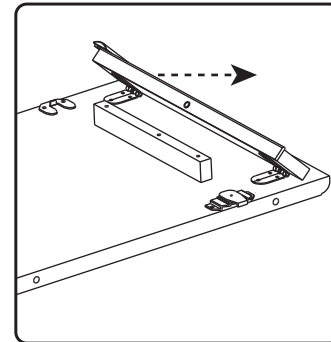
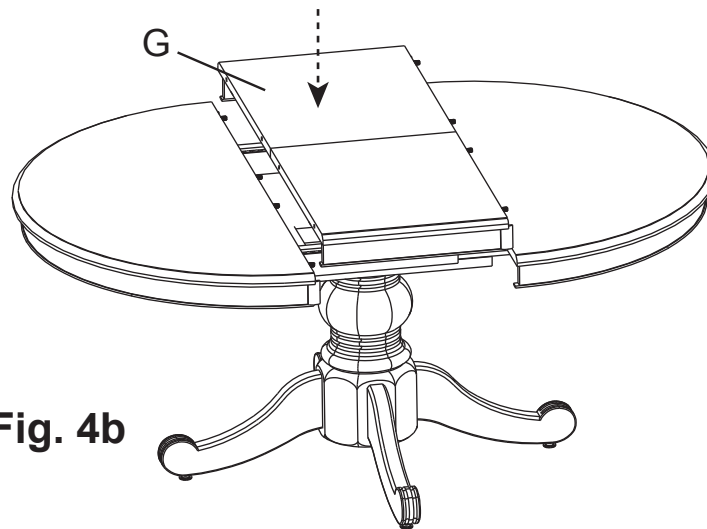

Fig. 4b



4. To insert the leaf, flatten out the Leaf Assembly (G) as shown in Figure 4. Flip open the Apron on each end of the leaf assembly as in Figure 4a and turn it right-side up. Place it in the open space between the table ends and line up the guide pins and holes. Gently push the table ends until the leaf fits snugly. See Figure 4b. Close the locks that are underneath the table.

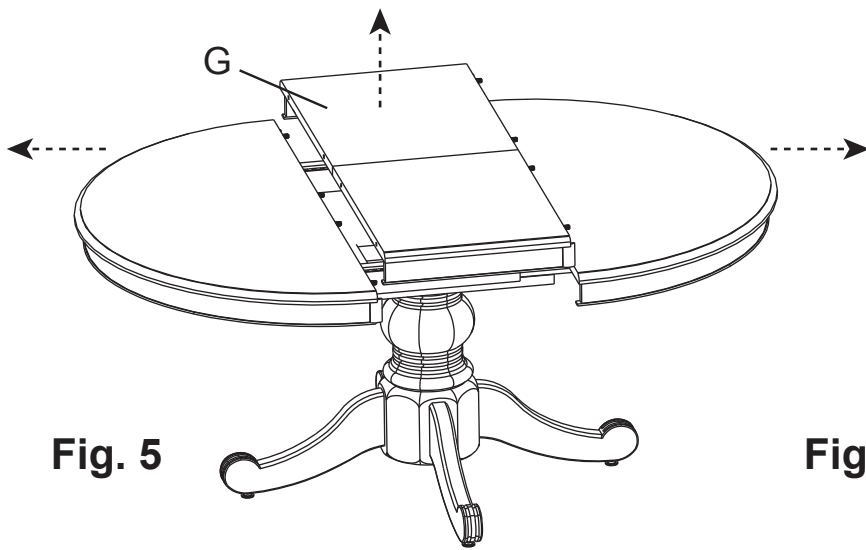

Fig. 5

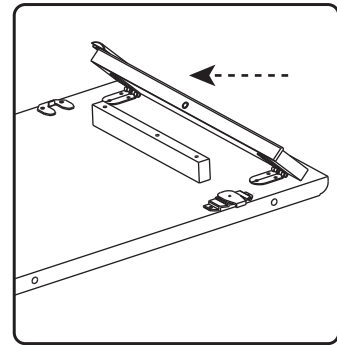

Fig. 5a

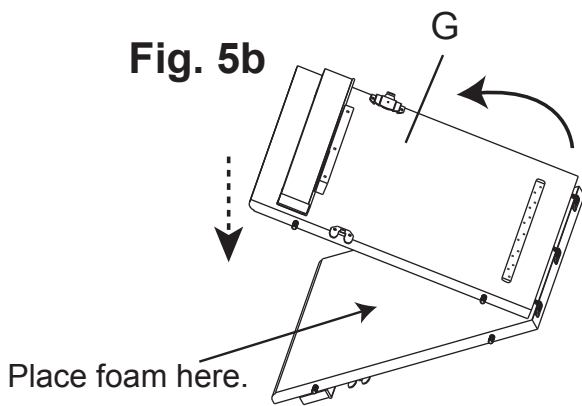

Fig. 5b

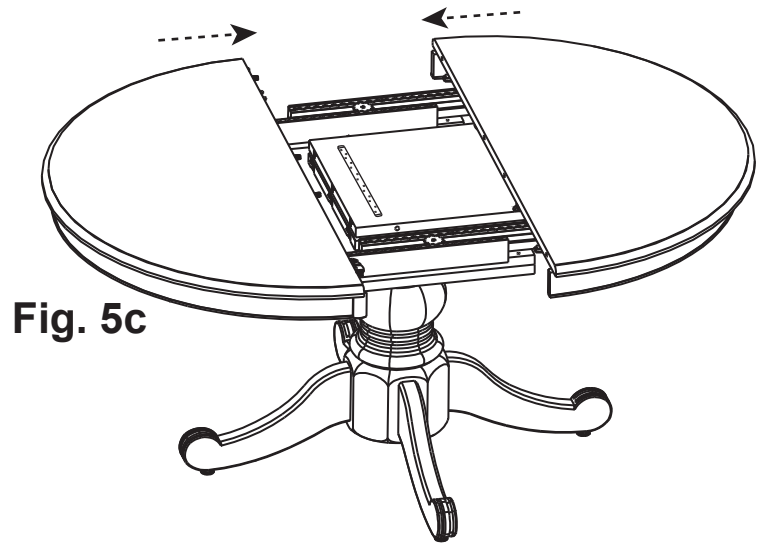

Fig. 5c

5. To remove the leaf, release the locks underneath the table. Gently pull away the table ends until the guide pins pull out of the holes. Lift out the leaf and place it upside down on a clean protected surface. See Figure 5. Push flat the apron on each end of the leaf. See Figure 5a. To protect the finish, place foam in between the leaves. Fold the leaf in half as shown in Figure 5b. Place the folded leaf in the storage area underneath the table ends and push the ends tightly shut. See Figure 5c.

Finishing Hints

Choosing the Finish:

1. Choose a finish that will meet your expectations for the product you are finishing. Are you matching existing furniture or do you want a "natural" finish? Is the piece to be functional, decorative or both? The answers to these questions may affect the type of finish you choose.
2. Use products of the same brand to ensure compatibility of products.
3. **ALWAYS** follow the stain manufacturer's instructions. Alder is a porous hardwood and often looks best when following the finishing directions for softwoods
4. We recommend using a wood conditioner under oil base stains.
5. Work in a well ventilated and well lit area.

Getting Started

1. **Assembly Instructions may contain special finishing information for that item.** Read both the Assembly Instructions and these Finishing Hints completely before beginning.
2. Sand the entire piece, using #220 grit sandpaper. Sand with the grain of the wood on flat surfaces and opposite the grain on turnings. Some parts are plywood. Be careful not to sand through the veneer. End grain (table top ends, seat edges, grooves on turnings, etc.) accepts more stain. Extra sanding in these areas with a #320 grit sandpaper will reduce stain absorption, creating a more evenly stained piece.
3. When sanding is completed, wipe the surface of your furniture with a cloth or tack rag. Make sure the item is free of dust before proceeding.

Staining

1. Read and follow label directions. Stir stain well before starting.
2. Test stain on an inconspicuous spot on your project, or use the sample chip if one is provided. The sample chip must be sanded in the same way as your furniture kit to ensure the piece will accept the stain similarly. Put at least one coat of your top coat over the stain sample, as it also affects the look of the stain. **Test every type of wood that is in your kit.** Some of our products include more than one type of wood, which may react differently to the stain color. Sample chips for the different woods may be included. It may be necessary to add a second coat of stain to lighter woods to match the darker woods in your kit.

Basic Equipment:

- | | | |
|--|---|--|
| <input type="checkbox"/> Rubber gloves | <input type="checkbox"/> Tack cloth | <input type="checkbox"/> #220 & #320 sandpaper |
| <input type="checkbox"/> Rags | <input type="checkbox"/> Drop cloth | <input type="checkbox"/> Mineral spirits |
| <input type="checkbox"/> Paper towels | <input type="checkbox"/> Paint brushes (bristle and foam) | <input type="checkbox"/> Masking Tape |
| <input type="checkbox"/> Q-tips | | |

3. Apply stain with a poly brush or lint-free cloth. Apply stain over a small area and wipe off excess. Working in small areas will make the color easier to control.
4. Q-tips are ideal for hard to reach areas.
5. Allow to dry thoroughly before proceeding.

Applying the Top Coat:

No top coat is required if using paint.

1. **Always read and follow all label directions.** Stir your finish coat gently, **do not shake.** It will create bubbles that are hard to remove.
2. **All surfaces** (including the underside of table tops and inside drawers) **must be sealed with at least one layer of a top coat.** This will help minimize wood swelling, shrinkage, warping and cupping due to changes in moisture content or temperature.
3. We recommend that you **apply a minimum of two coats when using polyurethane or varnish (especially on all table top and work surfaces).** Sand lightly between coats using a #320 grit sandpaper or 00 steel wool for the smoothest possible finish.
4. Some water-based finishes tend to raise the grain slightly. This can be easily controlled with this sanding step. However, do not use steel wool when using water-based finishes. Strands of steel fiber caught in the wood can cause rust spots when coated with any water-based product.

Painting:

1. For best results when painting, first coat the wood with a primer. An oil based primer would be best for a smooth finish. If you do not wish to use a solvent based primer, a water based primer would work almost as well.
2. Buy a quality brand paint. You may use a satin, semi-gloss, or gloss sheen. Apply a second coat for a smooth finish. Lightly sand between coats using a #320 grit sandpaper, so that the second coat will bond well. Repeat as desired.
3. Since there is such a variation between paint manufacturers, refer to your paint supplier for specific advice on using the paint that you purchase.