

Model #

2400AFGACa; 2400AFCAF McKenzie 3-Drawer Desk

AFGAC = Glazed Antique Cherry finish

AFCAF = Caffè finish

Assembly Instructions

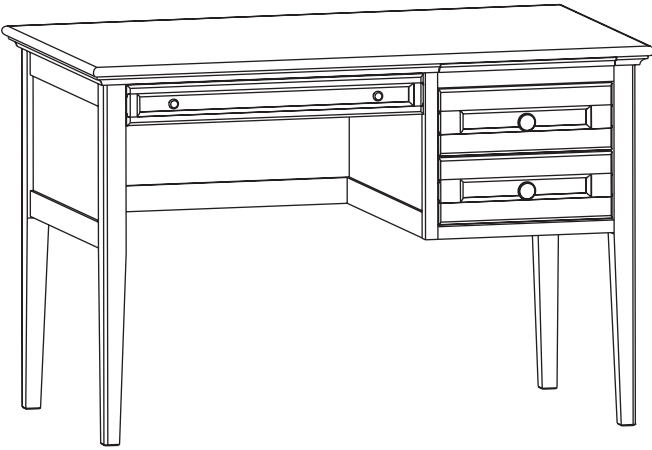

Congratulations!

This fine piece of furniture will make a gorgeous addition to your home. For the best results, read the Assembly Instructions before you begin your project.

IMPORTANT NOTES:

- For normal household use only. **Not** recommended to use this desk in a commercial setting.
- Use a protective pad when you use this piece as a writing surface.
- Before you begin your project, completely read the Assembly Instructions.
- Before you load or move this unit, tighten all screws and supports.
- Do not overload the drawers.
- Unload items before you move this unit.
- Store this item: 1- in its box; 2- in a dry place; 3- in temperatures that range from 40°F to 90°F (not on a cold and possibly damp cement floor).
- Periodically inspect your furniture for any loose glue joints, screws or any other problem that might affect the stability of your furniture. Tighten or repair as needed.

DESIGN SUBJECT TO CHANGE WITHOUT NOTICE.



CALL US FIRST! *Do not return this item to the store.*

Service Policy: We will replace any part that is defective, missing or damaged during assembly. For a replacement part, phone, fax, mail or email your request to the Whittier Wood Products customer service department.

Hours: Our friendly customer service staff can be reached Monday-Friday 7:00 a.m. to 5:00 p.m. (Pacific Time). You may leave a message 24 hours a day, seven days a week.

To Order: Provide the finish, the furniture model number (upper portion of this page), the part letter, production code, quantity needed, reason for replacement and your full name, address and telephone number.

Parts ship from our Eugene, Oregon factory within one or two business days from the time we receive your request. Please allow five to ten business days for delivery.

800-653-3336 • Outside the U.S. or Canada: 541-687-0213 • Fax: 541-687-2060
www.whittierwood.com • P.O. Box 2827 • Eugene, Oregon 97402, U.S.A.

**Whittier
Wood**
FURNITURE

P.O. Box 2827
Eugene, OR 97402 USA











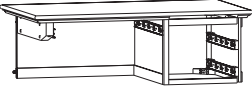

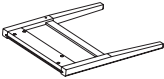
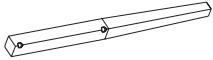
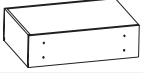

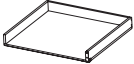

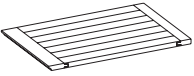
Production Code:

VN

10/11













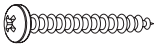

2400AFGACFa, 2400AFCAFa McKenzie 3-Drawer Desk — Parts List

Please identify the parts and check that quantities received match those on this list.
If you need to replace a part, refer to the following letter and model name.

Part	Description	Quantity
A	Case Assembly 	1
B	Top Assembly (attached) 	1
C	Left Side Assembly 	1
D	Leg 	2
E	Drawer (inserted) 	2
F	Drawer Face (installed) 	2
G	Keyboard Tray Box (inserted) 	1
H	Keyboard Tray Face (installed) 	1
Ia	Pull-out (installed) 	1
J	Drawer Slides (installed) 	3 sets
K	#6 x 3/4" Philtruss Screw (inserted) 	18
L	#6 x 1/2" Philtruss Screw (inserted) 	18
M	Roller Catch Kit (attached) 	1 set
N	Left Keyboard Hinge (attached) 	1
O	Right Keyboard Hinge (attached) 	1
Q	Knob (attached) 	2
R	#8 x 1-1/2" Machine Screw (installed) 	2
S	Small Knob (attached) 	2
T	4 x 35mm Machine Screw (installed) 	2

2400AFGACa, 2400AFCAFa McKenzie 3-Drawer Desk — Parts List continued

Please identify the parts and check that quantities received match those on this list.
If you need to replace a part, refer to the following letter and model name.

Part	Description	Quantity
Ua	Magnetic Push Lock (attached) 	1
V	#8 x 7/8" LoProfile Screw (inserted) 	8
W	#8 x 1-1/4" Pan Head Screw (inserted) 	20
X	#8 x 1-3/4" Pan Head Screw 	14 (13 inserted)
Y	#12 x 2-1/2" Pan Head Screw (inserted) 	5
ZA	#8 x 1-1/4" Black Screw (inserted) 	16
ZB	#8 x 2" Black Screw (inserted) 	2
ZC	Wood Dowel (inserted) 	1
ZD	Insert Nut (inserted) 	8
ZE	5/16" Flat Washer 	8
ZF	3/8" x 2-1/2" Hex Bolt 	8
ZG	Adjustable Glide (inserted) 	4
ZI	#6 x 1/2" Undercut Screw (inserted) 	8
ZJ	3mm x 12mm Pan Head Screw (inserted) 	2
ZK	1/4" x 20mm Insert Nut (inserted) 	4

2400AFGACa, 2400AFCAFa McKenzie 3-Drawer Desk Assembly Instructions

Tools Required: Phillips Screwdriver, 9/16" or Adjustable Wrench, Mallet or Padded Hammer

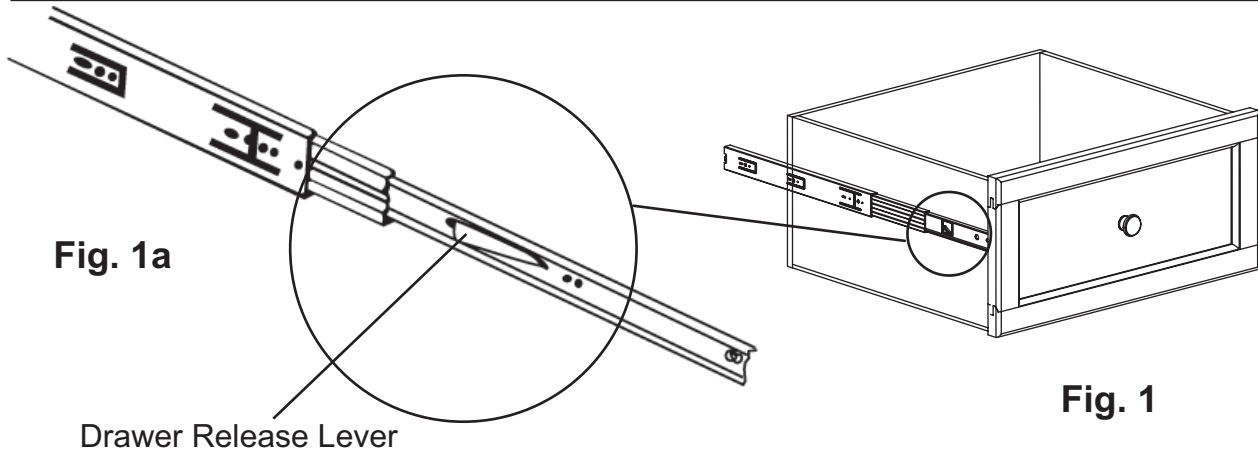

1. Remove the drawers from the Case Assembly (A). To do that, pull up on the left Drawer Release Lever while pushing down on the right Drawer Release Lever and pull out the drawer. See Figure 1a. Note where each drawer came from to make sure you place them back into their correct positions.

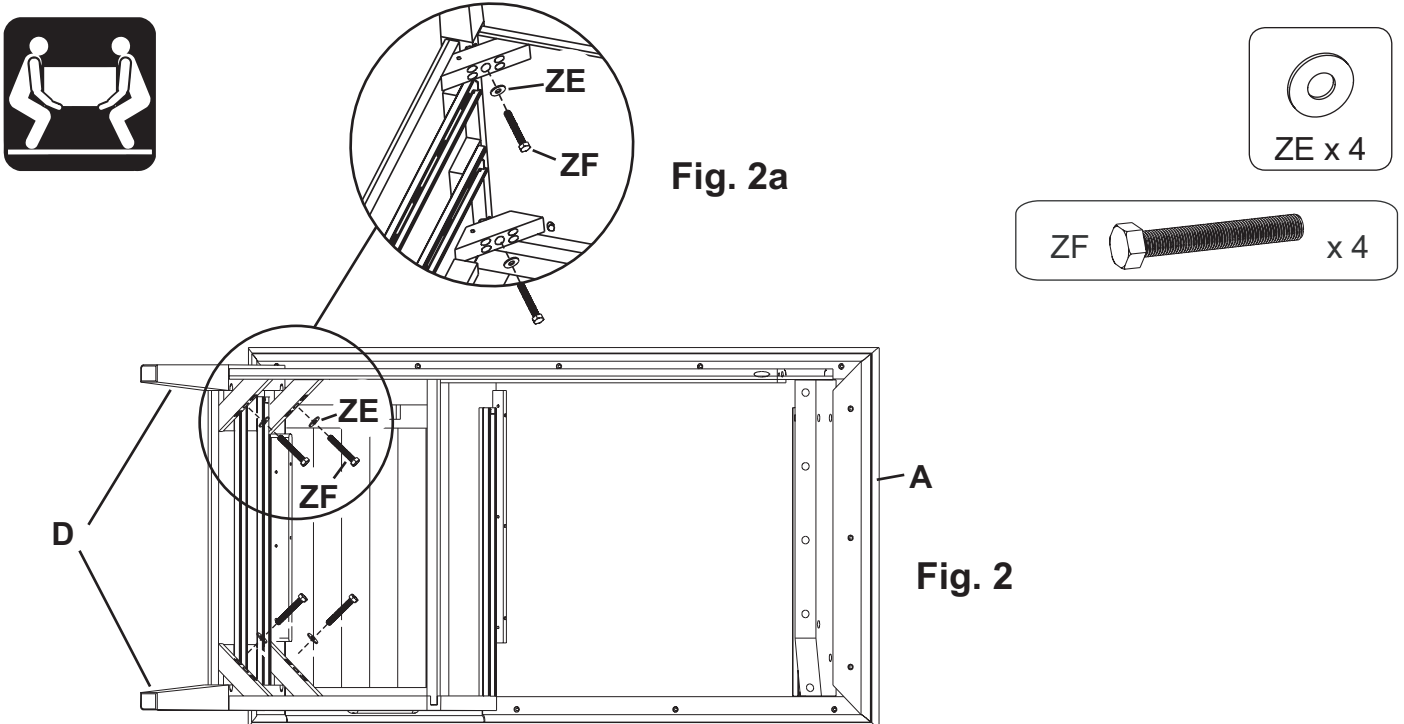

2. Turn the Case Assembly (A) upside-down on a clean protected surface. Be careful not to engage the touch-latch on the pull-out writing/working surface. Place a Leg (D) into the right front and back corners, making sure the drilled portions of the legs face the corner blocks. Insert four 3/8" x 2-1/2" Hex Bolts (ZF) with four 5/16" Flat Washers (ZE) through the corner blocks and into the Legs (D). Fasten securely. See Figures 2 and 2a.

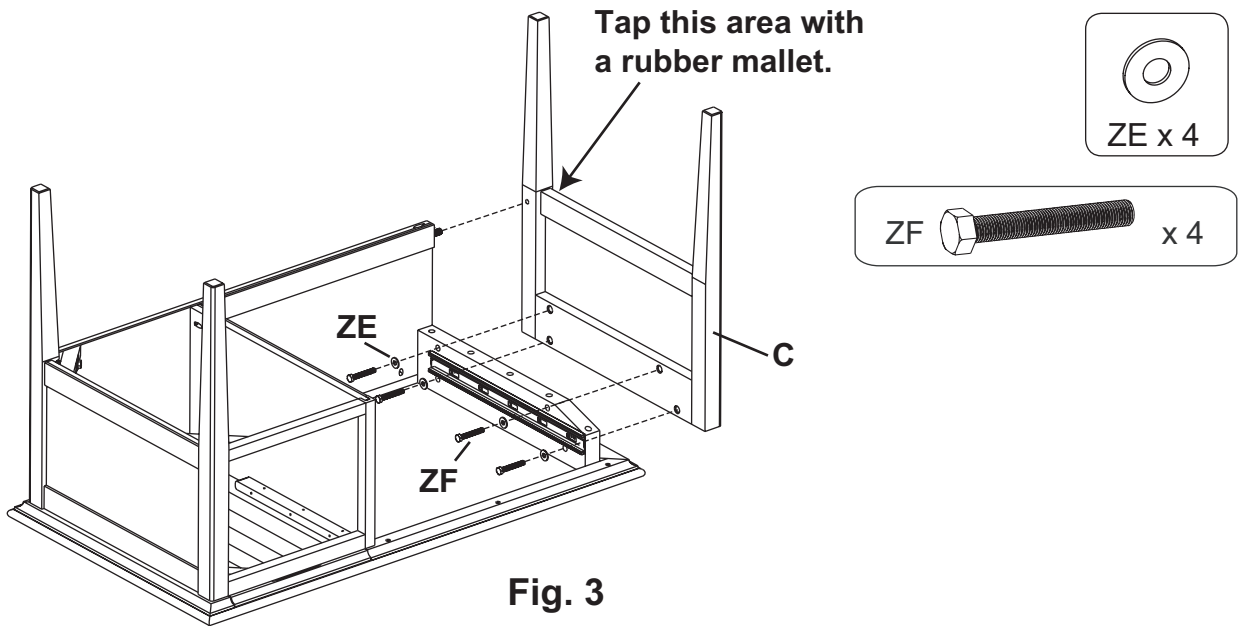

3. Attach the Left Side Assembly (C) to the drawer side of the case assembly with four 3/8" x 2-1/2" Hex Bolts (ZF) and four 5/16" Flat Washers (ZE). Fasten securely. Make sure the dowel is correctly seated in place by tapping the Left Side Assembly with a rubber mallet. See Figure 3.

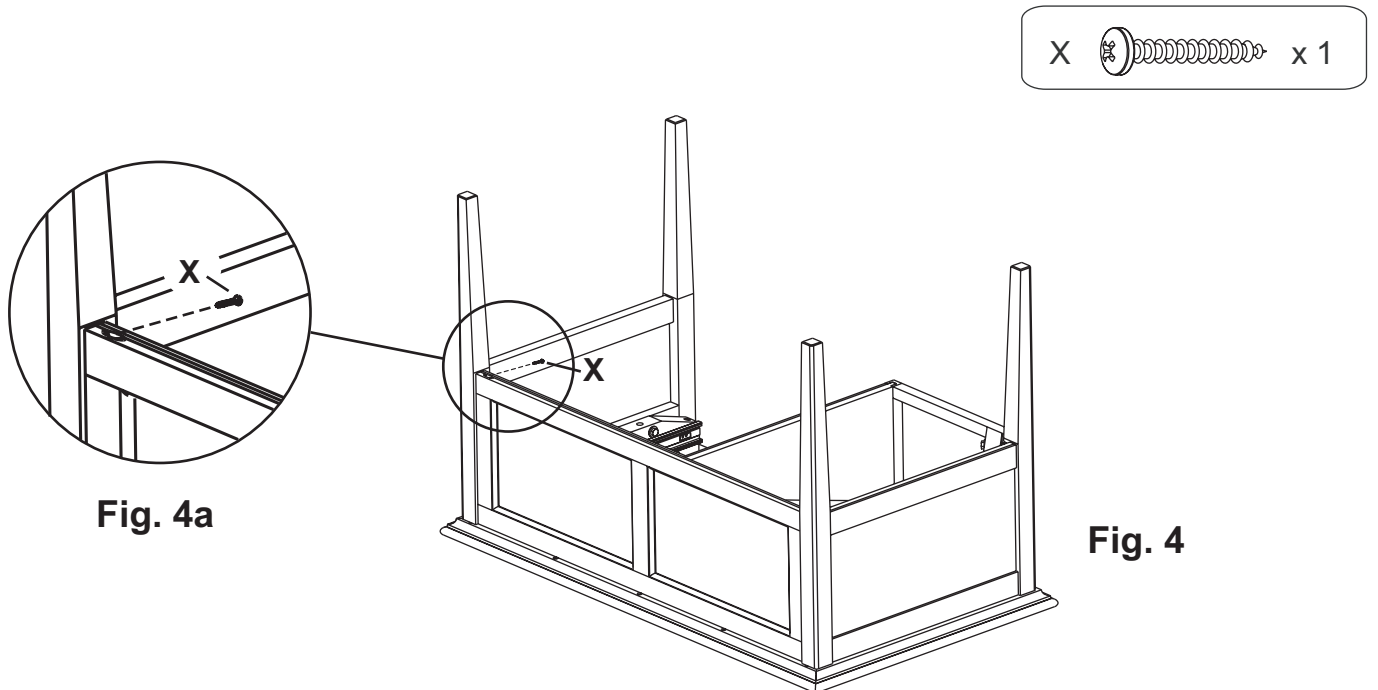

4. Using the pocket drilled hole as a guide, secure the back leg of the Left Side Assembly to the case assembly with one #8 x 1-3/4" Pan Head Screw. See Figures 4 and 4a.

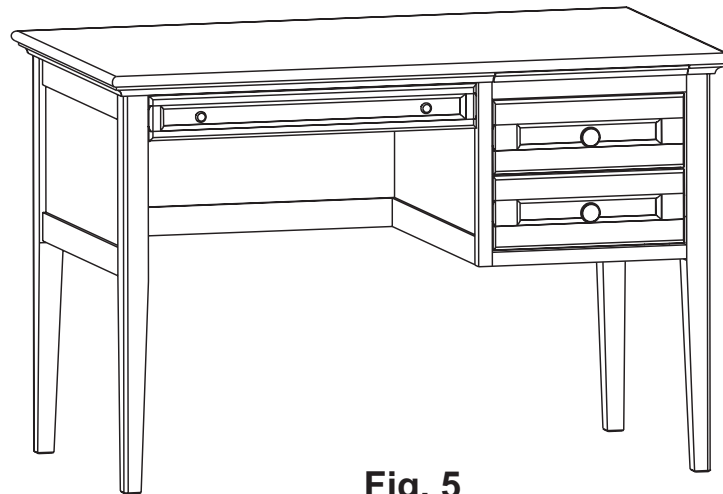

Fig. 5

5. Turn the table upright and insert the Drawers.
-

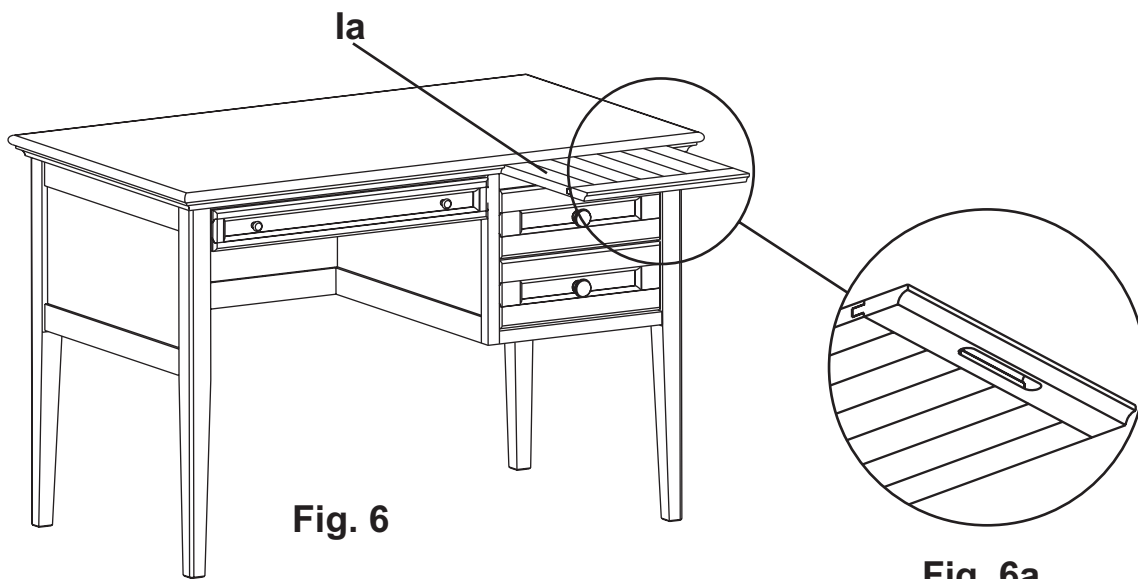
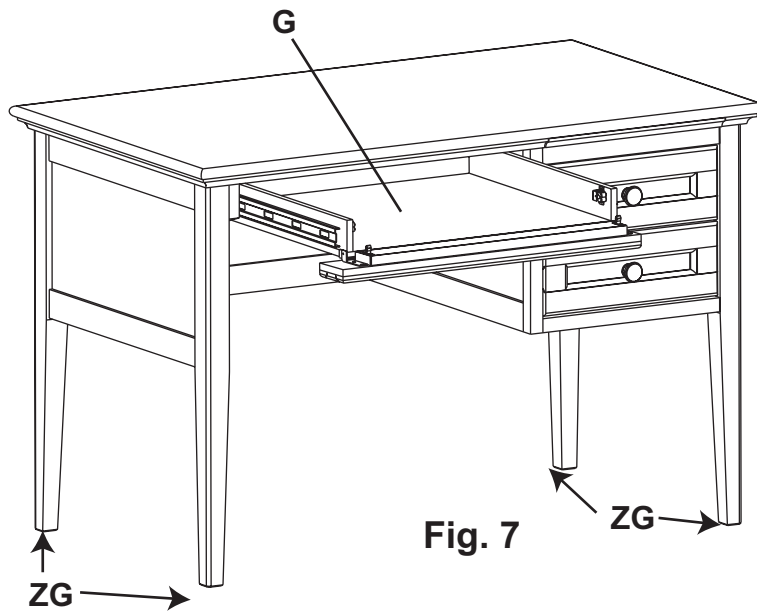

Fig. 6

Fig. 6a

6. This desk features a Pull-out (1a) that is above the two drawers on the right side. To access this feature, push firmly on the end of the pull-out. This releases the Push Lock. Grab on to the underside hand groove and gently pull. See Figures 6 and 6a.



7. The center drawer (G) can be used as a keyboard tray or utility drawer. To use it as a keyboard tray, open the drawer and pull down on the front. This unlocks the roller catches. To lock it back into place, push up on the drawer front. See Figure 7. The shortened drawer back allows easy cord access.



8. Place the desk at its final destination. To level the unit, rotate the Adjustable Glides (ZG) found on the bottoms of the legs.

9. Use a protective pad when using your furniture as a writing surface.