

56"W Pacific Media Console

Model #

2090AFGSPa; 2090AFCAF a

AFGAC = Glazed Spice finish

AFCAF = Caffè finish

Assembly Instructions

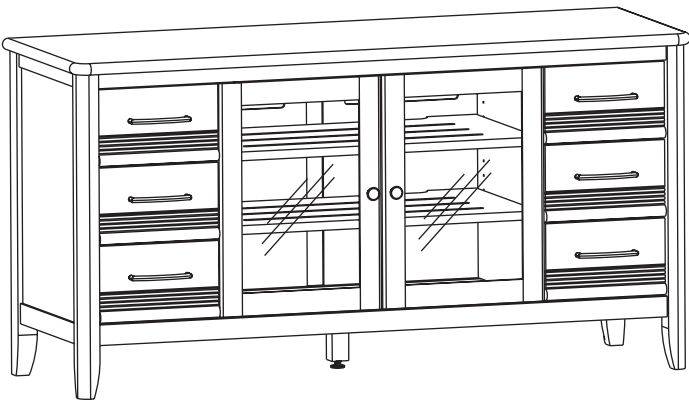

Congratulations!

This fine piece of furniture will make a gorgeous addition to your home. For the best results, read the Assembly Instructions before you begin your project.

! WARNING

Serious or fatal crushing injuries can occur from furniture tip-over. To help prevent tip-over:

- Place heaviest items in the bottom drawers.
- Unless specifically designed to accommodate, do not set TVs or other heavy objects on top of this product.
- Never allow children to climb or hang on drawers, doors or shelves.
- Never open more than one drawer at a time.

Correctly installing tipping restraints may reduce but will not eliminate the risk of tip-over.

! IMPORTANT NOTES:

- For normal household use only. **Not** recommended to use this product in a commercial setting.
- Unload items before you move this unit.
- Before you load or move this unit, tighten all screws and supports.
- Do not climb, sit or stand on this piece of furniture.
- Do not overload drawers or shelves on this unit.
- Handle the glass plates with care. Glass is fragile.
- Before you begin your project, completely read the Assembly Instructions.
- Store this item: 1- in its box; 2- in a dry place; 3- in temperatures that range from 40°F to 90°F (not on a cold and possibly damp cement floor).
- Periodically inspect your furniture for any loose glue joints, screws or any other problem that might affect the stability of your furniture. Tighten or repair as needed.
- This Assembly requires two people.

DESIGN SUBJECT TO CHANGE WITHOUT NOTICE.



CALL US FIRST! Do not return this item to the store.

Service Policy: We will replace any part that is defective, missing or damaged during assembly. For a replacement part, phone, fax, mail or email your request to the Whittier Wood Products customer service department.

Hours: Our friendly customer service staff can be reached Monday-Friday 7:00 a.m. to 5:00 p.m. (Pacific Time). You may leave a message 24 hours a day, seven days a week.

To Order: Provide the finish and furniture model number (upper portion of this page), the part letter, production code, quantity needed, reason for replacement and your full name, address and telephone number.

Parts ship from our Eugene, Oregon factory within one or two business days from the time we receive your request. Please allow five to ten business days for delivery.

800-653-3336 • Outside the U.S. or Canada: 541-687-0213 • Fax: 541-687-2060
www.whittierwood.com • P.O. Box 2827 • Eugene, Oregon 97402, U.S.A.

Production Code:

VN











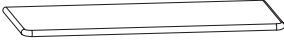

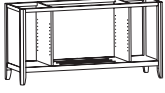







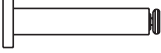

11/11

**Whittier
Wood**
FURNITURE

P.O. Box 2827
Eugene, OR 97402 USA

2090AFGSPa; 2090AFCAFa 56"W Pacific Media Console — Parts List











Please identify the parts and check that quantities received match those on this list.
If you need to replace a part, refer to the following letter and model name.

Part	Description	Quantity
A	Top (attached) 	1
B	Adjustable Shelf 	2
C	Case only 	1
D	Removable Back (installed) 	2
E	Door Frame (installed) 	2
G	Drawer Box (installed) 	6
H	Drawer Face (attached) 	6
I	Door Glass (installed) 	2
J	Glass Retainer 9 feet (installed) 	1
K	Drawer Slides (installed) 	6 sets
L	Shelf Bracket (attached) 	8
M	#6 x 1/2" Undercut Screw (inserted) 	8
N	#6 x 3/4" Philtruss Screws (installed) 	36
O	#6 x 1/2" Philtruss Screws (installed) 	36
P	Assembled Foot (attached) 	1
S	Small Adjustable Glide (inserted) 	5
T	#8 x 2" Black Screw (inserted) 	2
U	Knob (attached) 	2
V	#8 x 1-1/4" Machine Screw (attached) 	2
W	Handle (attached) 	6
Y1	Hinge (installed) 	4
Z1	Hinge Plate (installed) 	4
ZA	#6 x 3/4" P.O. Screw (installed) 	16

2090AFGSPa; 2090AFCAFa 56"W Pacific Media Console

— Parts List continued

Please identify the parts and check that quantities received match those on this list.
If you need to replace a part, refer to the following letter and model name.

Part	Description	Quantity
ZB	Drawer Stop (attached) 	4
ZC	Turn Button (attached) 	4
ZD	#6 x 5/8" Philtruss Screws (inserted) 	12
ZE	#8 x 1-1/4" Pan Head Screws (inserted) 	18
ZF	#8 x 1-3/16" Pan Head Screws (inserted) 	6
ZG	#8 x 1-1/4" Black Screws (inserted) 	29
ZH	#8 x 1" LoProfile Screws (inserted) 	24
ZI	Hex Bumper (attached) 	2
ZJ	#8 x 1-1/8" LoProfile Screws (inserted) 	4
ZK	Insert Nut (inserted) 	5
ZL	#8 x 1-5/8" Machine Screw (installed) 	12
TR	Furniture Tipping Restraint	2 sets

2090AFGSPa; 2090AFCAFa 56"W Pacific Media Console Assembly Instructions

Tool Required: Phillips Screwdriver



1. Place the console at its final destination. Rotate the Small Adjustable Glides (S) on the bottoms of the legs until the unit is level.

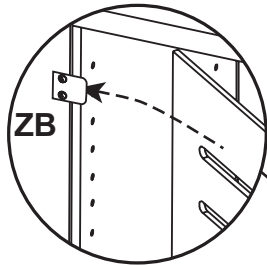

Fig. 2a

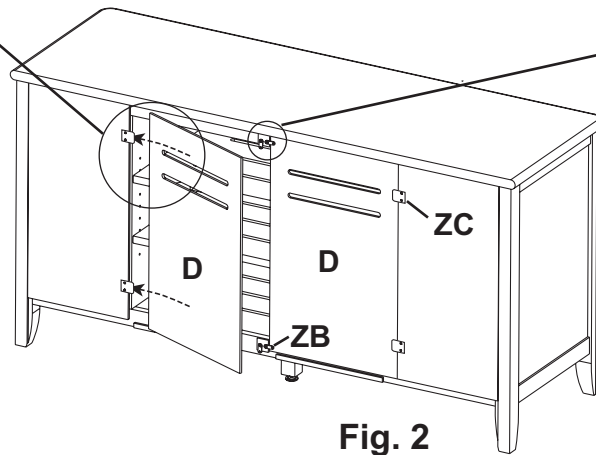
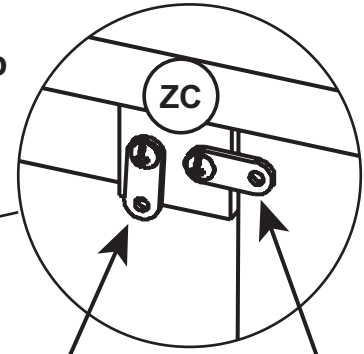

Fig. 2

Fig. 2b



Unlock Position Lock Position

2. You may want to remove the Removable Backs (D) so that you can fit your media units into the console more easily. To do so, unlock the Turn Button (ZC) as shown in Figures 2 and 2b. Slide the Backs away and place them off to the side. To put them back into place, slide the Backs behind the Drawer Stops (ZB) and position the Turn Button so that it is locked. See Figures 2a and 2b.

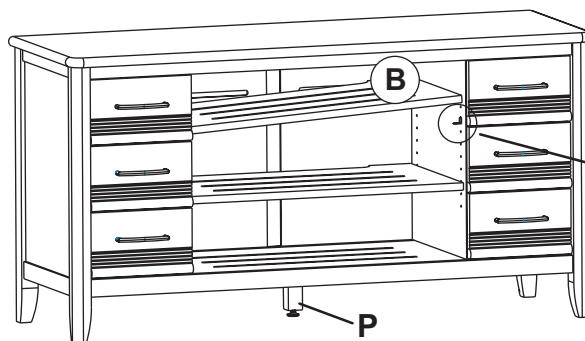

Fig. 3a

Door removed for illustration purposes

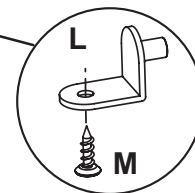
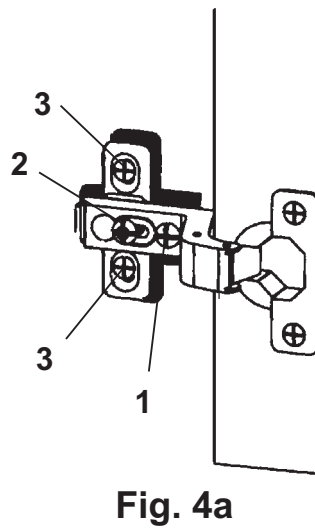
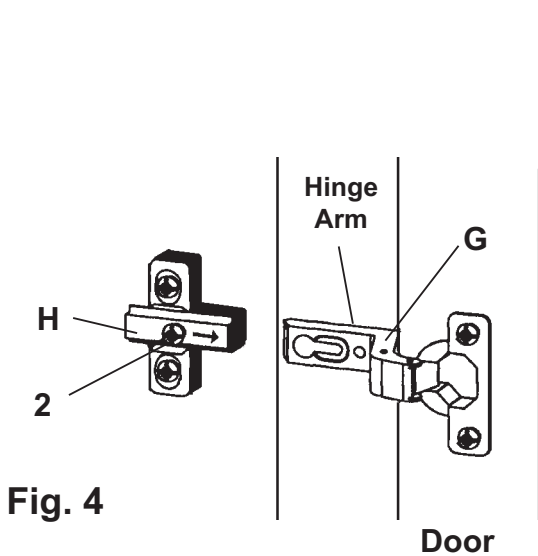

Fig. 3b

3. To move the Adjustable Shelves (B), remove the #6 x 1/2" Undercut Screws (M) and the Shelves (B). Place the Shelf Brackets (L) where you want them to be, replace the shelf and insert the screws. See Figures 3a and 3b.



Side adjustment 4mm (5/32")
 To move the door towards the side panel, loosen screw '1' and tighten screw '2'. To move the door away from the side panel, loosen screw '2' and tighten screw '1'.

Depth Adjustment 4mm (5/32")
 Loosen screw '2' (just one turn), adjust the door to the desired position and re-tighten the screw.

Height Adjustment 4mm (5/32")
 Loosen screw '3', adjust the door to the desired position and re-tighten the screw.

4. If you need to adjust the doors, follow the instructions above.

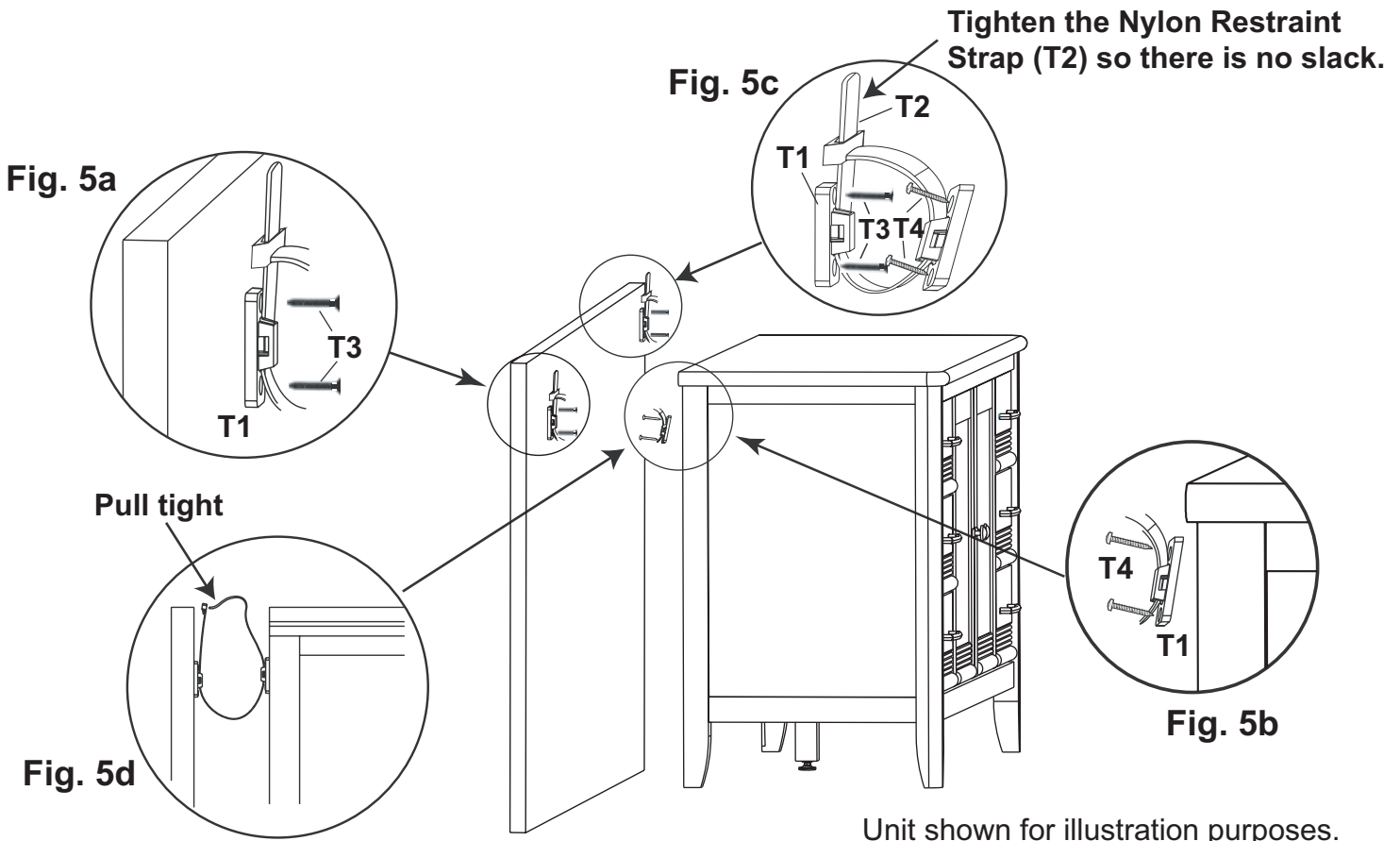

Tipping restraint:

5. Locate two studs in the wall behind the unit. Attach a Clip (T1) to one wall stud with two #8 x 2" Black Screws (T3). See Figure 5a. Attach a second clip to the unit with two #8 x 1" Pan Head Screws (T4). See Figure 5b. Connect the two clips with the Nylon Restraint Strap (T2). **Pull the Nylon Restraint Strap (T2) tight so there is no slack.** See Figures 5c and 5d. Repeat this procedure to attach the second tipping restraint. If you cannot locate two studs, purchase the proper wall attachment hardware for your type of wall and secure the unit.