

# 54"W Corner Media Console

Model #

# 2075AFGAC 2075AFCAF

**AFGAC = Glazed Antique Cherry finish**

**AFCAF = Caffè finish**

*Assembly Instructions*

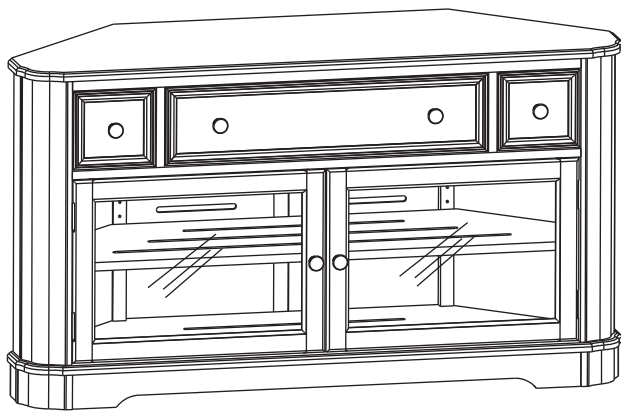

## **Congratulations!**

*This fine piece of furniture will make a gorgeous addition to your home. For the best results, read the Assembly Instructions before you begin your project.*

## **⚠ WARNING**

**Serious or fatal crushing injuries can occur from furniture tip-over. To help prevent tip-over:**

- Place heaviest items in the bottom drawers.
- Unless specifically designed to accommodate, do not set TVs or other heavy objects on top of this product.
- Never allow children to climb or hang on drawers, doors or shelves.
- Never open more than one drawer at a time.

**Use of tip-over restraints may only reduce but not eliminate the risk of tip-over.**



## **IMPORTANT NOTES:**

- For normal household use only. **Not** recommended for commercial use.
- Unload items before you move this unit.
- Before you load or move this unit, check to make sure all screws and supports are tight.
- Do not climb, sit or stand on this piece of furniture.
- Do not overload drawers or shelves on this unit.
- Handle the glass plates with care. Glass is fragile.
- Before you begin your project, completely read the Assembly Instructions.
- Store this item: 1- in its box; 2- in a dry place; 3- in temperatures that range from 40°F to 90°F (not on a cold and possibly damp cement floor).
- Periodically inspect your furniture for any loose glue joints, screws or any other problem that might affect the stability of your furniture. Tighten or repair as needed.
- This Assembly requires two people.

**DESIGN SUBJECT TO CHANGE WITHOUT NOTICE.**



**CALL US FIRST! Do not return this item to the store.**

**Service Policy:** We will replace any part that is defective, missing or damaged during assembly. For a replacement part, directly contact the Whittier Wood Products customer service department by phone, fax, mail or email.

**Hours:** Our friendly customer service staff can be reached Monday-Friday 7:00 a.m. to 5:00 p.m. (Pacific Time). You may leave a message 24 hours a day, seven days a week.

**To Order:** Designate the finish, provide the furniture model number (upper left corner of this page), the part letter, production code, quantity needed, reason for replacement, your full name, address and telephone number.

*Parts ship from our Eugene, Oregon factory within one or two business days from the time we receive your request. Please allow five to ten business days for delivery.*

**800-653-3336** • Outside the U.S. or Canada: 541-687-0213 • Fax: 541-687-2060  
www.whittierwood.com • P.O. Box 2827 • Eugene, Oregon 97402, U.S.A.

Production Code:

VN

07/10

**Whittier  
Wood**  
FURNITURE

P.O. Box 2827  
Eugene, OR 97402 USA

# 2075AFGAC; 2075AFCAF 54"W Corner Media Console — Parts List

Please identify the parts and check that quantities received match those on this list.

If you need to replace a part, refer to the following letter and model name.



A — Top  
— Qty. 1 (attached)

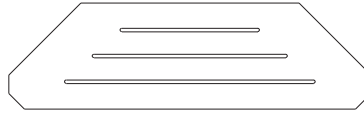

B — Adjustable Shelf  
— Qty. 1

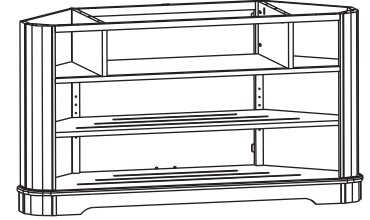

C — Case Only — Qty. 1

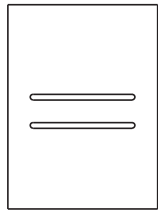

D — Removable Back  
— Qty. 2

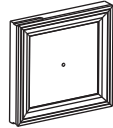

E — Small Door  
— Qty. 2 (installed)

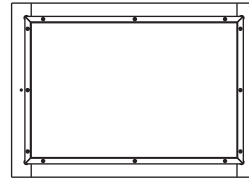

F — Glass Door Frame  
— Qty. 2 (installed)

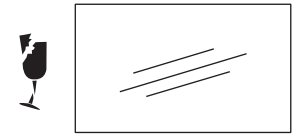

G — Door Glass  
— Qty. 2 (installed)

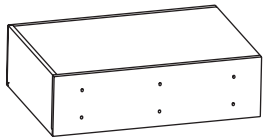

H — Drawer Box  
— Qty. 1 (installed)



I — Drawer Face  
— Qty. 1 (installed)



J — Door Glass Support Rail  
— Qty. 4 (Attached)



K — Door Glass Support Stile  
— Qty. 4 (Attached)



L — Shelf Bracket  
— Qty. 4 (attached)



M — #6 x 1/2" Undercut  
Screw — Qty. 4 (inserted)

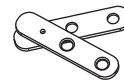

N — Angle Hinge  
— Qty. 4 (attached)

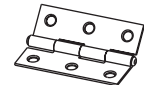

O — Hinge — Qty. 4  
(attached)



P — #6 x 5/8" Flat Head  
Screw — Qty. 40 (attached)



Q — Magnetic Plate  
— Qty. 4 (attached)



R — #6 x 5/8" Undercut  
Screw — Qty. 8 (inserted)

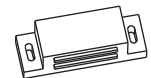

S — Magnetic Catch  
— Qty. 4 (installed)



T — #6x5/8" Philtruss  
Screw — Qty. 20 (inserted)



U — Drawer Slides  
— Qty. 1 set (installed)



V — #6x3/4" Philtruss  
Screw — Qty. 6 (inserted)



W — #6x1/2" Philtruss  
Screw — Qty. 6 (inserted)

# 2075AFGAC; 2075AFCAF 54"W Corner Media Console

## — Parts List continued

Please identify the parts and check that quantities received match those on this list.  
If you need to replace a part, refer to the following letter and model name.

---



X — Knob  
— Qty. 6 (attached)



Y — #8 x 1-1/4" Machine  
Screw — Qty. 4 (installed)



ZA — M4 x 41mm Machine  
Screw — Qty. 2 (installed)



ZB — Drawer Stop  
— Qty. 4 (attached)



ZC — Turn Button  
— Qty. 4 (attached)



ZD — #6 x 3/4" Brass Flat  
Head Screw — Qty. 24  
(inserted)



ZE — #8x1-1/4" Pan Head  
Screw — Qty. 38 (inserted)



ZF — #8 x 1-1/4" Black  
Screw — Qty. 8 (inserted)



ZG — #8 x 2" Black  
Screw — Qty. 16 (inserted)



ZH — #8 x 1" LoProfile  
Screw — Qty. 4 (inserted)



ZI — Insert Nut  
— Qty. 2 (Inserted)



ZJ — Small Adjustable Glide  
— Qty. 2 (installed)



ZK — Tack Glide  
— Qty. 3 (inserted)

TR — Tipping Restraint  
— Qty. 2

# 2075AFGAC; 2075AFCAF 54"W Corner Media Console Assembly Instructions

Tool Required: Phillips Screwdriver

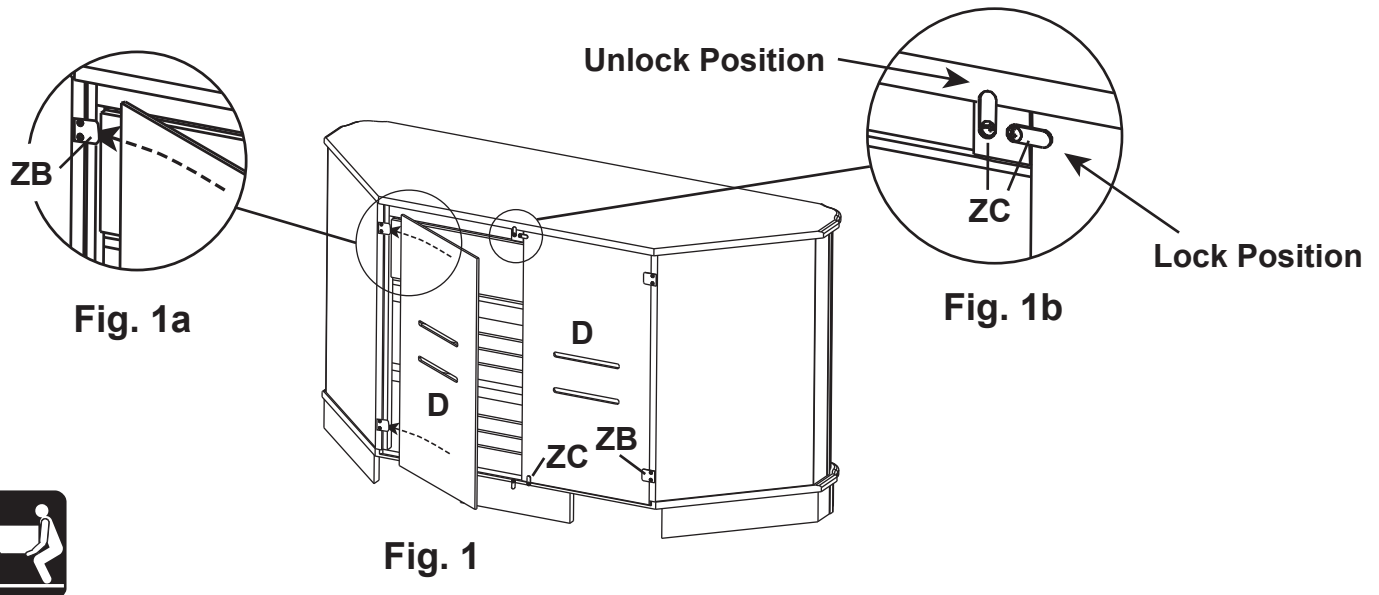

1. Move the unit to its final destination. To level the unit, turn the Small Adjustable Glides (ZJ) found at the bottom left and right front corners.

To place your media components and access wires more easily, you may want to remove the Removable Backs (D). To do so, unlock the Turn Buttons (ZC) as shown in Figures 1 and 1a. Slide the Backs away and place them off to the side. To put them back into place, slide the Backs behind the Drawer Stops (ZB) and position the Turn Button so that it is locked. See Figure 1b.

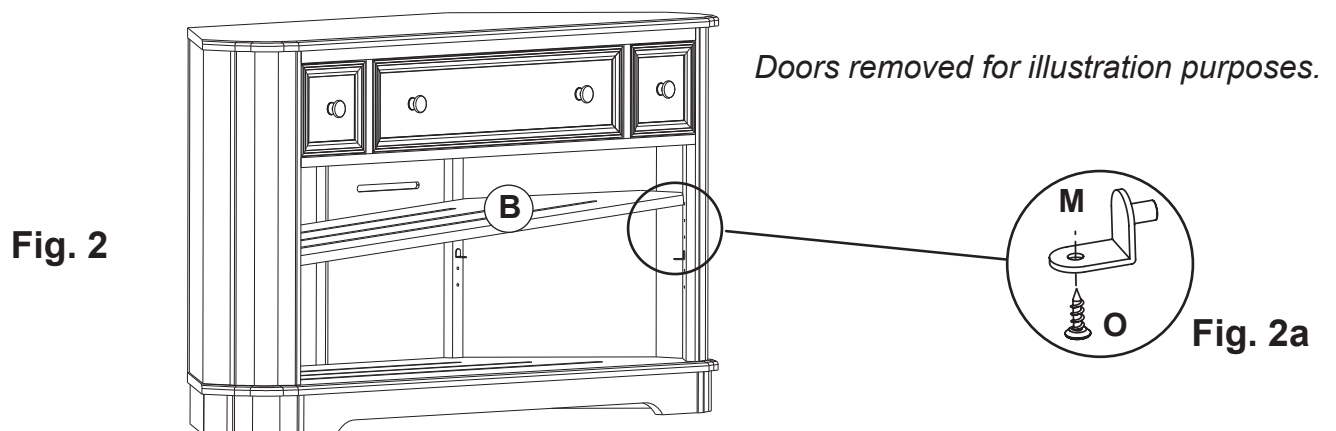

2. To move the Adjustable Shelf (B), remove the #6 x 1/2" Undercut Screws (M) and the Shelf (B). Reposition the Shelf Brackets (L) to the desired positions, replace the shelf and insert the screws. See Figures 2 and 2a.

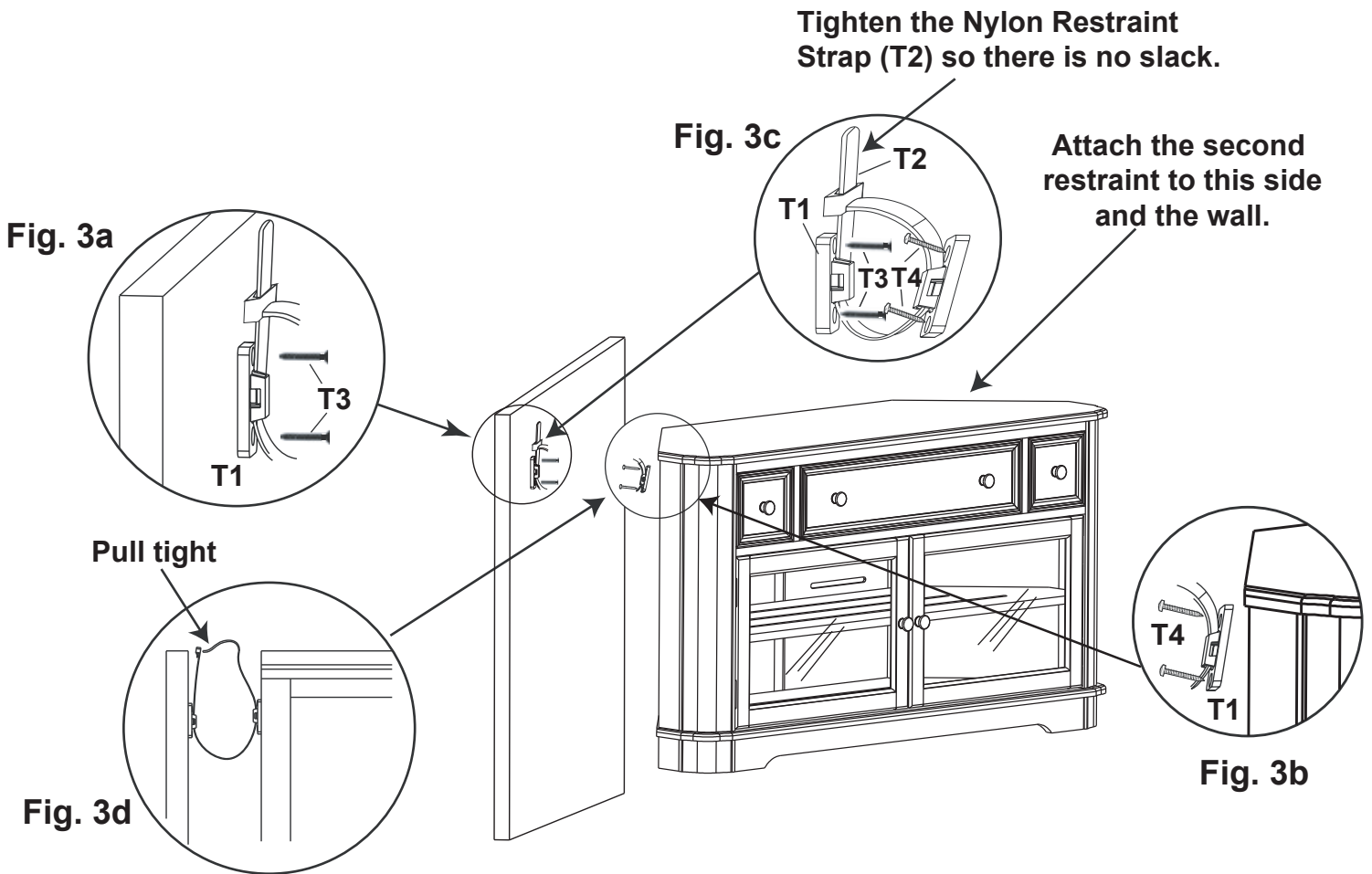

**Tipping restraint:**

3. Locate one stud in each wall against the unit. Attach a Clip (T1) to one wall stud with two #8 x 2" Black Screws (T3). See Figure 3a. Attach a second clip to the unit with two #8 x 1" Pan Head Screws (T4). See Figure 3b. Connect the two clips with the Nylon Restraint Strap (T2). **Pull the Nylon Restraint Strap (T2) tight so there is no slack.** See Figures 3c and 3d. Repeat this procedure to attach the second tipping restraint. If you cannot locate two studs, purchase the proper wall attachment hardware for your type of wall and secure the unit.