

Model #

202Wb Pub Base

Assembly Instructions

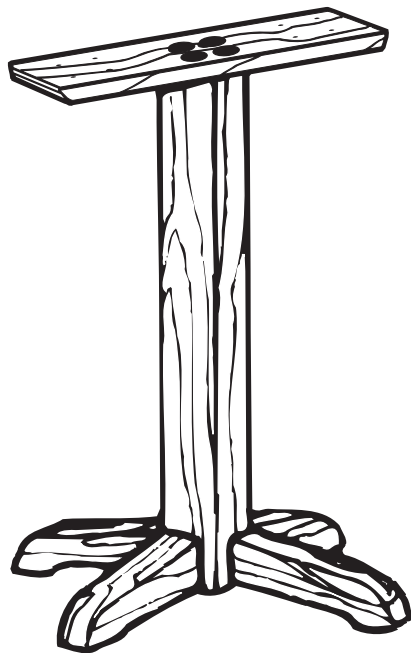

Create
A Table

TOP SOLD
SEPARATELY



IMPORTANT NOTES:

- For normal household use only. **Not** recommended for commercial use.
- Do not climb, sit or stand on this piece of furniture.
- Before you begin your project, completely read the Assembly Instructions and Finishing Hints.
- Store this item: 1- in its box; 2- in a dry place; 3- in temperatures that range from 40° to 90° (not on a cold and possibly damp cement floor).
- Periodically inspect your furniture for any loose glue joints, screws or any other problem that might affect the stability of your furniture. Tighten or repair as needed.
- This assembly requires two people.

DESIGN SUBJECT TO CHANGE WITHOUT NOTICE.

Congratulations!

This fine piece of furniture will make a gorgeous addition to your home. For the best results, read the Assembly Instructions and Finishing Hints before you begin your project.



CALL US FIRST! *Do not return this item to the store.*

Service Policy: We will replace any part that is defective, missing or damaged during assembly. Please contact Whittier Wood Products customer service department directly by phone, fax, mail or email for a replacement part.

Hours: Our friendly customer service staff can be reached Monday-Friday 7:00 a.m. to 5:00 p.m. (Pacific Time). You may leave a message 24 hours a day, seven days a week.

To Order: Provide the furniture model number (upper left corner of this page), the part letter, production code, quantity needed, reason for replacement, your full name, address and telephone number.

Parts ship from our Eugene, Oregon factory within one or two business days from the time we receive your request. Please allow five to ten business days for delivery.

800-653-3336 • Outside the U.S. or Canada: 541-687-0213 • Fax: 541-687-2060
www.whittierwood.com • P.O. Box 2827 • Eugene, Oregon 97402, U.S.A.

Whittier
Wood
FURNITURE

P.O. Box 2827
Eugene, OR 97402 USA

Production Code:

VN

01/10

202Wb Pub Base — Parts List

Before you begin to assemble this unit, identify each part and make sure the quantities received match what is on this list.

If you need to replace a part, please refer to the following list for the part name and letter code.

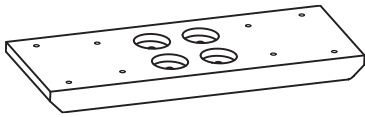

A — Top Support — Qty. 1



B — Pedestal — Qty. 1



Cb — Foot — Qty. 4

HARDWARE

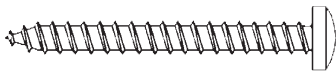

D — #12 x 2" Pan Head Screw — Qty. 8



E — 3/8" x 4-1/2" Hanger Bolt — Qty. 4 (inserted)



F — Curved Washer — Qty. 4



G — 3/8" Hex Nut — Qty. 4

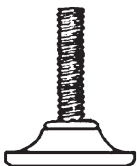

H — Adjustable Glide — Qty. 4 (inserted)



J — 5/16" Washer — Qty. 4



K — 5/16" x 3" Lag Bolt — Qty. 4

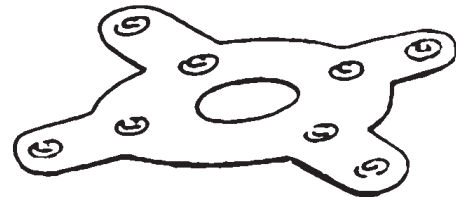

L — Star Plate — Qty. 1

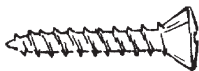

M — #10 x 1" Oval Head Screw — Qty. 8

N — Insert Nut — Qty. 4 (inserted)

202Wb Pub Base Assembly Instructions

Tools Required: Phillips screwdriver, 5/32" Drill bit, Drill, Adjustable wrench, Hammer, Wood glue
*To make this assembly easier and eliminate the need to drill pilot holes,
use a Phillips bit on a variable speed drill.*

We recommend that you finish the top and pedestal before you assemble your table.

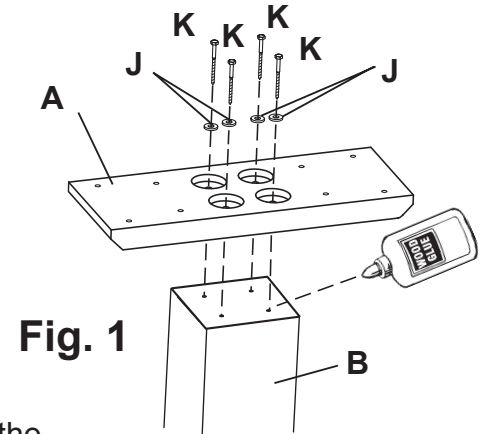

NOTE: Rub a little bit of soap on the threads of the Lag Bolts to help them screw in more easily.

1. Spread a thin layer of glue on the top of the Pedestal (B). Place the Top Support (A) so that the four countersunk holes face up. Align the countersunk holes in the Top Support with the holes in the top of the Pedestal. Start all four 5/16" x 3" Lag Bolts (K) into the Pedestal as shown in Figure 1. Tighten the screws firmly, but do not over-tighten, because that could strip the wood. If you do strip the wood in the Pedestal, spread a bit of glue on a small wedge of wood or on a couple of wooden match sticks and pound them into the stripped hole. Allow this to dry several hours and then solidly tighten the bolts.

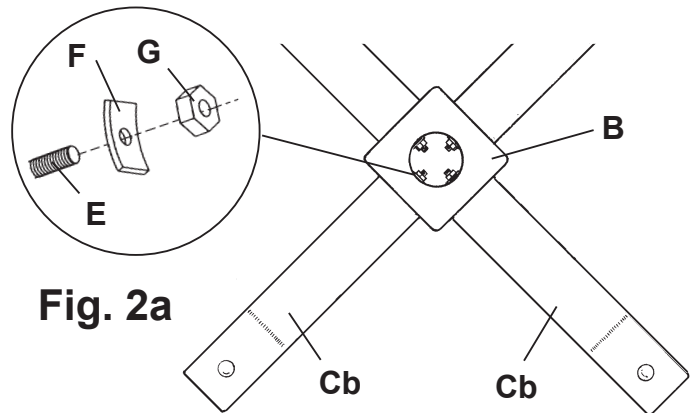
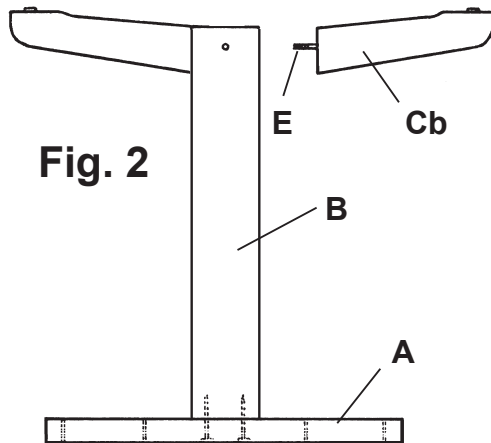

2. Turn the Pedestal assembly upside down on a clean, protected surface. Place the Hanger Bolt (E) that is in a Foot (Cb) through the hole in the base of the Pedestal. Place a Curved Washer (F) and a 3/8" Hex Nut over the Hanger Bolt and tighten. See Figures 2 and 2a. Repeat for the other three feet. Do not twist the feet to tighten the hanger bolts. **Doing so will scrape and mar the pedestal!**

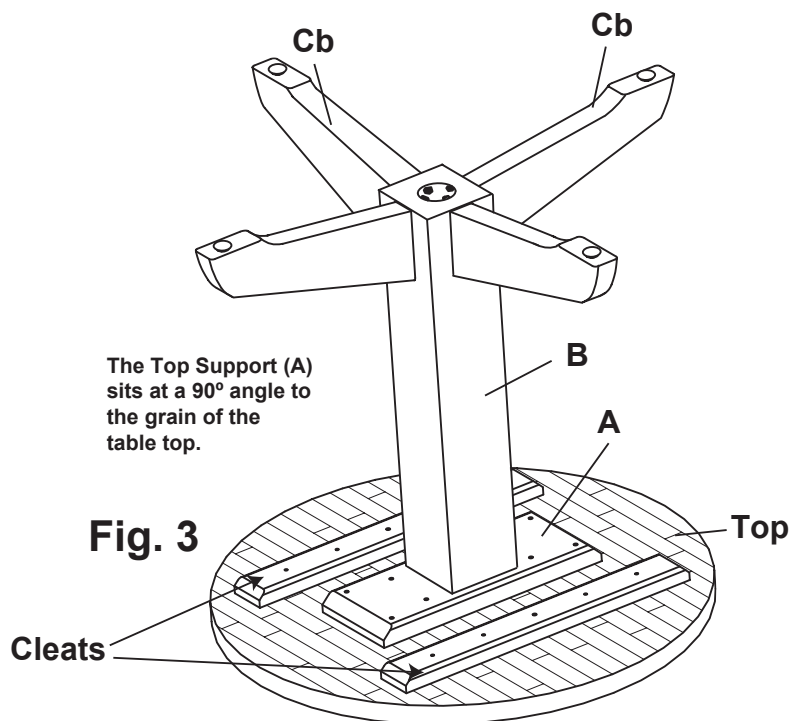

3. Turn the table top face-down on a clean, protected surface. Center the base on the top between the cleats. It is important to make sure the direction of the wood grain in the Top Support (A) is placed at a right angle (opposite) to the direction of the wood grain of the table top. This will prevent the table top from warping. See Figure 3.

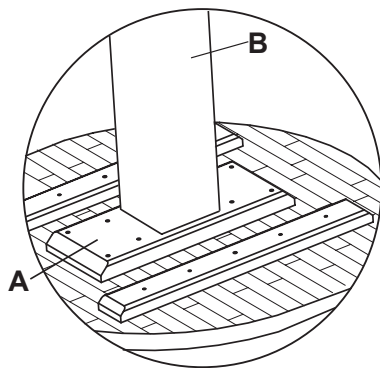

Fig. 4

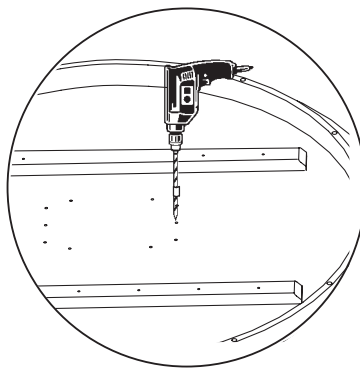

Fig. 4a

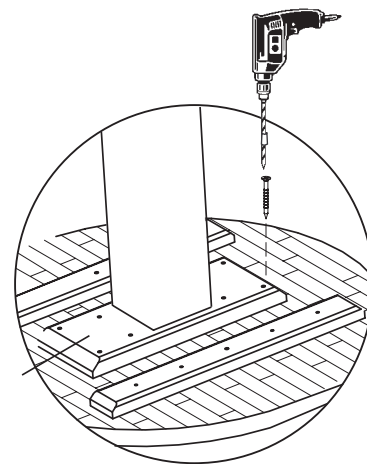

Fig. 4b

4. Place #12 x 2" Pan Head Screws (D) into the holes of the Top Support (A) and tap them lightly with a hammer to center punch or mark the screw locations on the bottom side of the table top. See Figures 4 and 4a. Move the table base away and, using a 1/8" drill bit (or smaller), drill the eight marked pilot holes. Drill the holes 3/4" deep. To prevent accidentally drilling through the table top, mark the drill bit with a piece of tape 3/4" from the tip of the drill bit. Stop drilling when the edge of the tape meets wood. See Figure 4b.

5. Put the table base back into position and solidly tighten the #12 x 2" Pan Head Screws (D) into the table top. Note: If you rub a bit of soap on the threads, it will help the screws to drill in more easily.

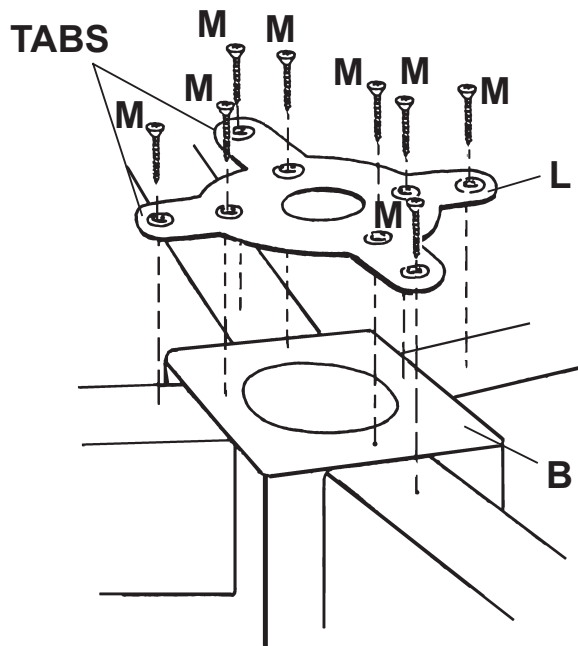

Fig. 6

- Center the Star Plate (L) on the bottom of the Pedestal (B) so that the tabs align with the legs as shown in Figure 6. Mark the location of the four screw holes that are nearest to the center of the plate and punch these marks with a nail, or drill with a 1/8" drill bit. Drill the holes 3/4" deep. To prevent yourself from accidentally drilling through, mark the drill bit with a piece of tape 3/4" away from the end of the drill bit. Stop drilling when wood meets tape. Insert #10 x 1" Oval Head Screws (M) in the four center holes and tighten until the plate is seated firmly against the base. This will cause the tabs on the Star Plate to conform to the angles of the feet. Using #10 x 1" Oval Head Screws (M), attach the tabs to the feet through the outer holes. See Figure 6.



- Turn the table upright. When you have placed the table where you want it located, rotate the Adjustable Glides (H) found at the bottoms of the feet to level the table.

Finishing Hints

Choosing the Finish:

1. Choose a finish that will meet your expectations for the product you are finishing. Are you matching existing furniture or do you want a "natural" finish? Is the piece to be functional, decorative or both? The answers to these questions may affect the type of finish you choose.
2. Use products of the same brand to ensure compatibility of products.
3. **ALWAYS** follow the stain manufacturer's instructions. Alder is a porous hardwood and often looks best when following the finishing directions for softwoods
4. We recommend using a wood conditioner under oil base stains.
5. Work in a well ventilated and well lit area.

Getting Started

1. **Assembly Instructions may contain special finishing information for that item.** Read both the Assembly Instructions and these Finishing Hints completely before beginning.
2. Sand the entire piece, using #220 grit sandpaper. Sand with the grain of the wood on flat surfaces and opposite the grain on turnings. Some parts are plywood. Be careful not to sand through the veneer. End grain (table top ends, seat edges, grooves on turnings, etc.) accepts more stain. Extra sanding in these areas with a #320 grit sandpaper will reduce stain absorption, creating a more evenly stained piece.
3. When sanding is completed, wipe the surface of your furniture with a cloth or tack rag. Make sure the item is free of dust before proceeding.

Staining

1. Read and follow label directions. Stir stain well before starting.
2. Test stain on an inconspicuous spot on your project, or use the sample chip if one is provided. The sample chip must be sanded in the same way as your furniture kit to ensure the piece will accept the stain similarly. Put at least one coat of your top coat over the stain sample, as it also affects the look of the stain. **Test every type of wood that is in your kit.** Some of our products include more than one type of wood, which may react differently to the stain color. Sample chips for the different woods may be included. It may be necessary to add a second coat of stain to lighter woods to match the darker woods in your kit.

Basic Equipment:

- | | | |
|--|---|--|
| <input type="checkbox"/> Rubber gloves | <input type="checkbox"/> Tack cloth | <input type="checkbox"/> #220 & #320 sandpaper |
| <input type="checkbox"/> Rags | <input type="checkbox"/> Drop cloth | <input type="checkbox"/> Mineral spirits |
| <input type="checkbox"/> Paper towels | <input type="checkbox"/> Paint brushes (bristle and foam) | <input type="checkbox"/> Masking Tape |
| <input type="checkbox"/> Q-tips | | |

3. Apply stain with a poly brush or lint-free cloth. Apply stain over a small area and wipe off excess. Working in small areas will make the color easier to control.
4. Q-tips are ideal for hard to reach areas.
5. Allow to dry thoroughly before proceeding.

Applying the Top Coat:

No top coat is required if using paint.

1. **Always read and follow all label directions.** Stir your finish coat gently, **do not shake.** It will create bubbles that are hard to remove.
2. **All surfaces** (including the underside of table tops and inside drawers) **must be sealed with at least one layer of a top coat.** This will help minimize wood swelling, shrinkage, warping and cupping due to changes in moisture content or temperature.
3. We recommend that you **apply a minimum of two coats when using polyurethane or varnish (especially on all table top and work surfaces).** Sand lightly between coats using a #320 grit sandpaper or 00 steel wool for the smoothest possible finish.
4. Some water-based finishes tend to raise the grain slightly. This can be easily controlled with this sanding step. However, do not use steel wool when using water-based finishes. Strands of steel fiber caught in the wood can cause rust spots when coated with any water-based product.

Painting:

1. For best results when painting, first coat the wood with a primer. An oil based primer would be best for a smooth finish. If you do not wish to use a solvent based primer, a water based primer would work almost as well.
2. Buy a quality brand paint. You may use a satin, semi-gloss, or gloss sheen. Apply a second coat for a smooth finish. Lightly sand between coats using a #320 grit sandpaper, so that the second coat will bond well. Repeat as desired.
3. Since there is such a variation between paint manufacturers, refer to your paint supplier for specific advice on using the paint that you purchase.