

Model #

197Wa

Fluted Pedestal Table Base

Assembly Instructions

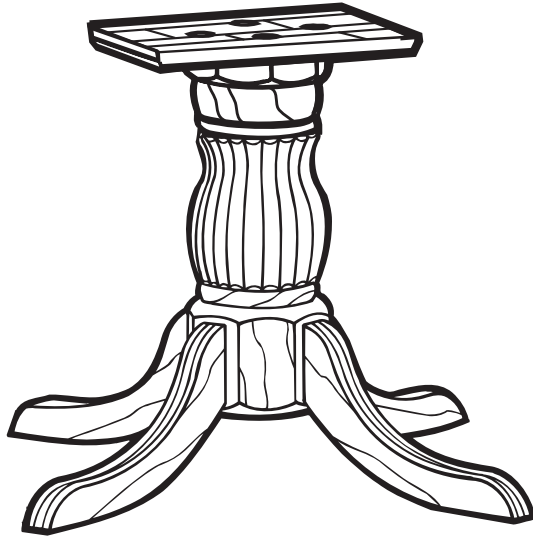

**TOP SOLD
SEPARATELY**

Congratulations!

*This fine piece of furniture will make a handsome addition to your home. For the best results, start by reading both the Assembly Instructions and Finishing Hints **before** you begin your project.*

**For normal household use only.
NOT recommended for commercial use.**



Do not climb, sit or stand on this piece of furniture.

DESIGN SUBJECT TO CHANGE WITHOUT NOTICE.

John Greenleaf
FURNITURE
Presented by Whittier Wood Products

P.O. Box 2827
Eugene, OR 97402 USA



CALL US FIRST!

DO NOT RETURN ITEM TO STORE

Service Policy: We will replace any parts which are defective, missing or damaged during assembly. Please contact Whittier Wood Products customer service department directly (by phone, fax, mail or email) for replacement parts.

Hours: Our friendly customer service staff can be reached Monday-Friday 7:00 a.m. to 5:00 p.m. (Pacific Time). A message can be left 24 hours a day, 7 days a week.

To Order: Provide the complete furniture model number, part letter, production code, quantity needed, reason for replacement and your full name and address along with a telephone number in case we need to contact you.

Parts ship from our Eugene, Oregon factory within 1 or 2 business days from the time we receive the request. Please allow 5-10 business days for delivery.

800-653-3336

Outside U.S. or Canada: 541-687-0213

Fax: 541-687-2060 • www.whittierwood.com

Mail: P.O. Box 2827 • Eugene, Oregon 97402, U.S.A.

IMPORTANT NOTES:

- Read both the Assembly Instructions and Finishing Hints completely before beginning.
- Store the parts: 1) in their box; 2) in a dry place; 3) in temperatures ranging from 40° to 90°. (Not on a cold, possibly damp, cement floor.)
- Inspect your furniture periodically for any loose glue joints or screws, or any other problem which may be affecting the stability of your furniture. Tighten or repair as needed.

Production Code:

VN

Rev. 1/07

197Wa Fluted Pedestal Table Base — Parts

BEFORE BEGINNING ASSEMBLY,
check that the quantities of the parts received match those on parts list below.

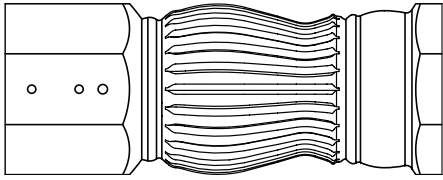

A — Pedestal — Qty. 1

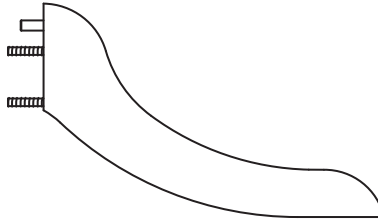

Ba — Foot — Qty. 4

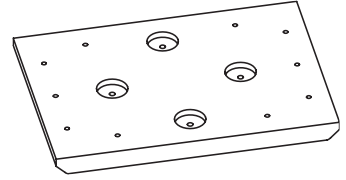

C — Top Support — Qty. 1

HARDWARE



D — T-Nut — Qty. 4

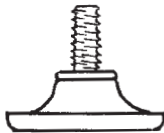

E — Adjustable Glide — Qty. 4

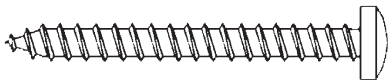

G — #12x2" Pan Head Screw
— Qty. 10



H — 3/8" Hex Nut — Qty. 8



I — 5/16"x3" Lag Bolt — Qty. 4



J — 5/16" Washer — Qty. 12



F — 3/8"x4½" Hanger Bolt (Inserted) — Qty. 8

197Wa Fluted Pedestal Table Base

ASSEMBLY INSTRUCTIONS

TOOLS REQUIRED:

Phillips Screwdriver, 9/16" Wrench, 1/2" Wrench, 5/32" Drill Bit and Drill, Wood Glue, Padded Hammer or Mallet

*We recommend using a Phillips bit on a variable speed drill.
This will make assembly easier and will eliminate the need for pre-drilling.*

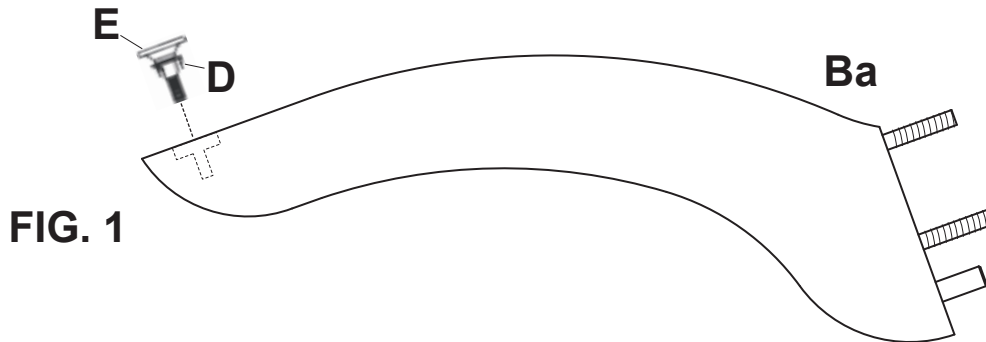

- 1) Screw an Adjustable Glide (E) into each T-Nut (D). Cover the bottom of the Glides with a cloth to protect them and lightly hammer them into the Feet (Ba).

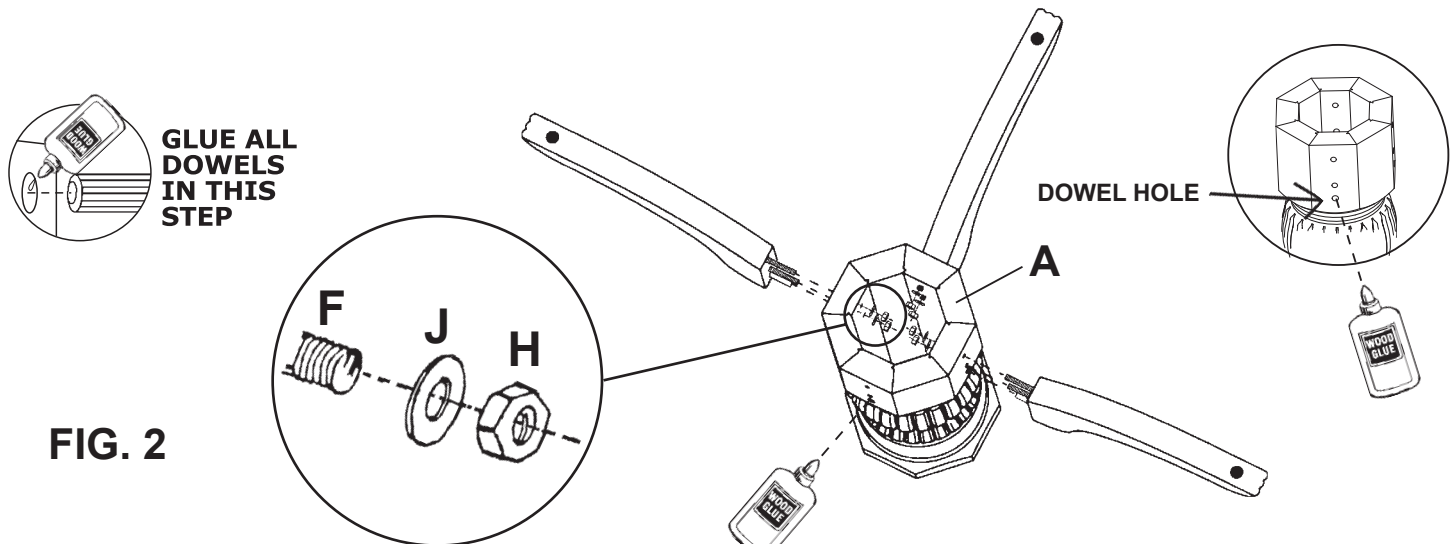

- 2) Apply a light film of glue in the each of the four dowel holes in the Pedestal (A), the dowel holes are the holes farthest from the end in each group of three. Place the Hanger Bolts (F) in the feet through the holes in the pedestal so that the dowel goes into the glued hole. Tap feet into place with padded hammer. Fasten in place with 5/16" Washer (J) and 3/8" Nut (H) over each bolt.

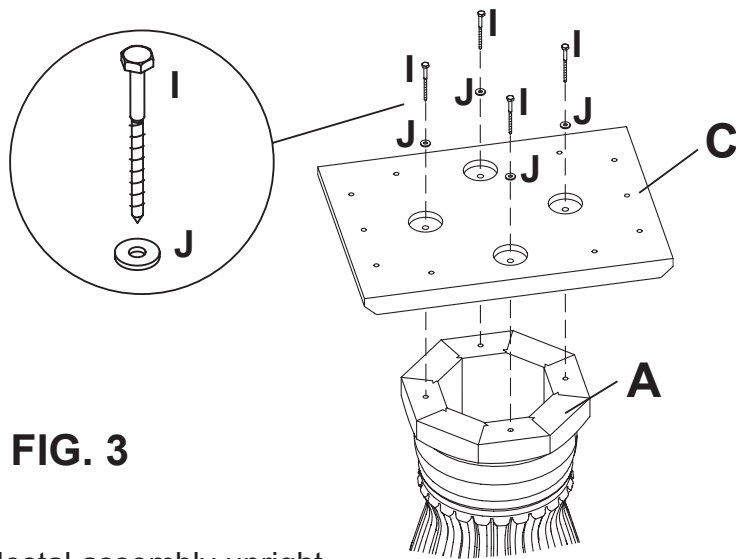

FIG. 3

3) Stand the pedestal assembly upright.

The four counter sunk holes in the top support must face up. Align the counter sunk holes with the holes in the top of the pedestal. Insert a 5/16"x3" Lag Bolt (I) with a 5/16" Washer (J) into each hole and tighten securely.

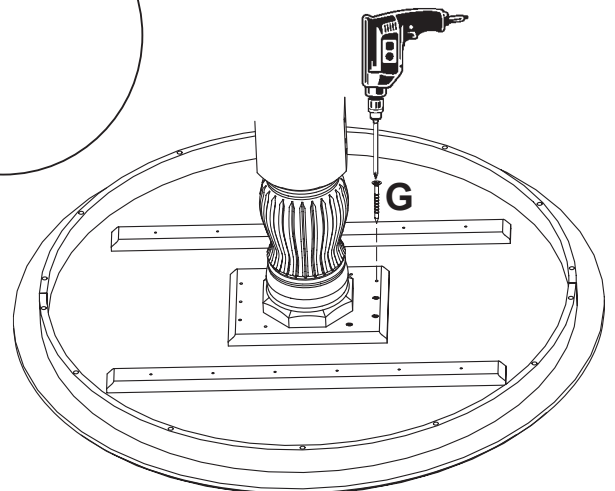
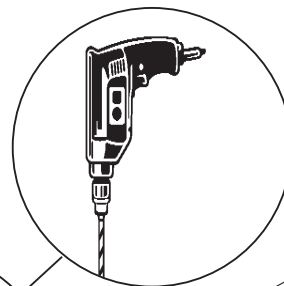
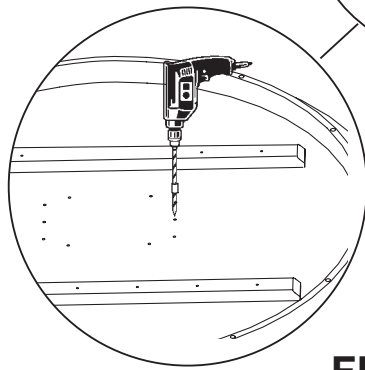
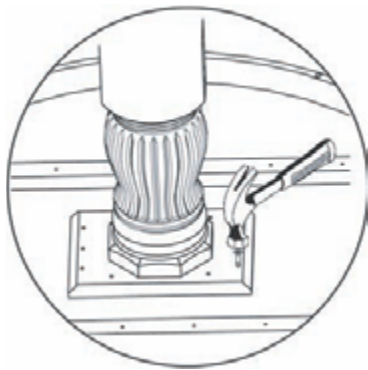
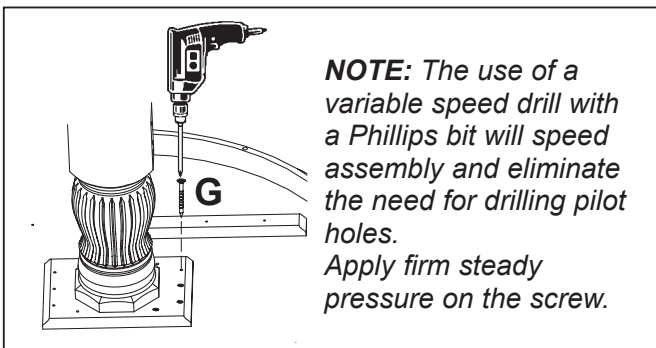

FIG. 4

4) With the Table Top laying face down on a protected surface, center the top support on the table top. Place a #12x2" Pan Head Screw (G) in each hole and tap them lightly with a hammer to center punch the screw location on the underside of the top.

Move the top support away and use a 5/32" drill bit to drill the ten pilot holes 3/4" deep (*drilling the pilot holes is not necessary if you are using a variable speed drill with a Phillips bit*). To prevent accidentally drilling through the table top, mark the drill bit with a piece of tape 3/4" from the end.

Replace the top support over the holes and insert the #12x2" Pan Head Screws (G).