

Model #

145W

Arrowback Counterstool

Assembly Instructions

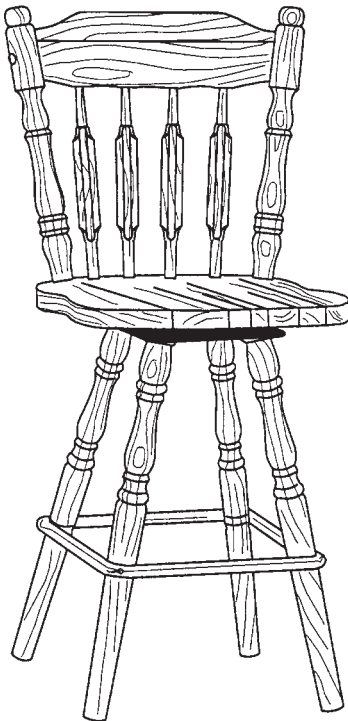

Congratulations!

*This fine piece of furniture will make a handsome addition to your home. For the best results, start by reading both the Assembly Instructions and Finishing Hints **before** you begin your project.*

**For normal household use only.
NOT recommended for commercial use.**



Do not climb or stand on this piece of furniture.

DESIGN SUBJECT TO CHANGE WITHOUT NOTICE.



P.O. Box 2827
Eugene, OR 97402 USA



CALL US FIRST!

DO NOT RETURN ITEM TO STORE

Service Policy: We will replace any parts which are defective, missing or damaged during assembly. Please contact Whittier Wood Products customer service department directly (by phone, fax, mail or email) for replacement parts.

Hours: Our friendly customer service staff can be reached Monday-Friday 7:00 a.m. to 5:00 p.m. (Pacific Time). A message can be left 24 hours a day, 7 days a week.

To Order: Provide the complete furniture model number (upper left corner of this page), part letter, production code, quantity needed, reason for replacement and your full name and address along with a telephone number in case we need to contact you.

Parts ship from our Eugene, Oregon factory within 1 or 2 business days from the time we receive the request. Please allow 5-10 business days for delivery.

800-653-3336

Outside U.S. or Canada: 541-687-0213

Fax: 541-687-2060 • Email: info@whittierwood.com
Mail: P.O. Box 2827 • Eugene, Oregon 97402, U.S.A.

IMPORTANT NOTES:

- Read both the Assembly Instructions and Finishing Hints completely before beginning.
- Store the parts: 1) in their box; 2) in a dry place; 3) in temperatures ranging from 40° to 90°. (Not on a cold, possibly damp, cement floor.)
- Inspect your furniture periodically for any loose glue joints or screws, or any other problem which may be affecting the stability of your furniture. Tighten or repair as needed.

Production Code:

145W Arrowback Counterstool

TOOLS REQUIRED:

Adjustable or 1/2" Wrench, Hammer or Rubber Mallet, 1/8" Drill Bit, Drill, Phillips Head Screwdriver & Wood Glue.

BEFORE BEGINNING ASSEMBLY, check that the quantities of the parts received match those on the parts list below.

PART	DESCRIPTION	QTY.	PART	DESCRIPTION	QTY.
A	Seat	1	H	5/16" x 3" Lag Bolts	4
BB	Legs	4	I	5/16" Washers	4
C	Back	1	J	#10 x 1½" Brass Screws	4
D	Back Post	2	K	#12 x 1" Pan Head Screws	4
E	Back Spindle	4	L	#8 x 1¾" Pan Head Screws	2
F	Swivel	1	M	Wedges	2
G	Brass Plated Ring	1	N	Wood Buttons	2

ASSEMBLY INSTRUCTIONS

IMPORTANT:
READ GLUING HINTS
BEFORE ASSEMBLING!
 Not intended for use by children
 without adult supervision.

TO DRILL THE SEAT:

1) Turn the top of the swivel (F) approximately 1/8 turn in relation to the bottom of the swivel. Center the swivel on the bottom of the seat (A) as shown in FIGURE 1. The holes for the screws in the swivel will line up with the indentations on the seat. Remove the swivel and drill 1/8" diameter pilot hole 1/2" deep, in the center of each indentation. (**Do not** attach the swivel at this time.)

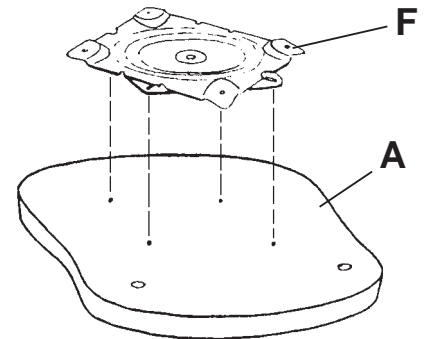

FIG. 1

TO ATTACH THE LEGS TO THE SWIVEL:

2) The top ends of the legs are pre-drilled. Fasten one leg (B) to each corner of the swivel (F) with a 5/16" x 3" lag bolt (H) and a 5/16" washer (I) as shown in FIGURE 2. Do not over tighten the bolts as you may strip the wood.

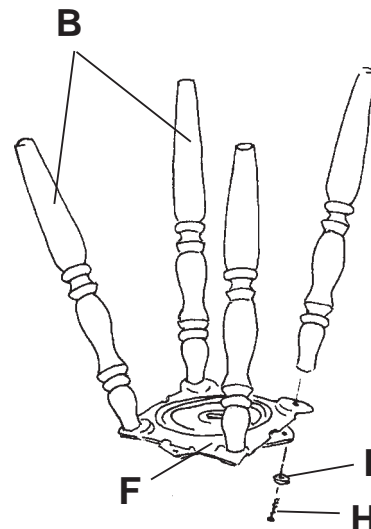

FIG. 2

TO ATTACH THE BACK SPINDLES:

3) Spread glue evenly into the four center holes in the top of the seat (A). Insert chucked ends of the four back spindles (E) into these holes, as shown in FIGURE 3.

TO ATTACH BACK AND BACK POSTS:

4) Spread glue evenly in the 2" oblong holes in the back posts (D). Put the back (C) and back posts (D) together as shown in FIGURE 3. Spread glue thinly but evenly in the four holes in the bottom of the back (C) and in the two outside holes in the seat. (Be careful not to use too much glue or it will ooze out onto the surface to be finished.) One at a time, insert the back posts (D) into these holes while working the back spindles (E) into holes in the back. Turn the back spindles (E) so that the flat portions follow the curve of the back (C). It may be necessary to use a rubber mallet or hammer that has been padded to pound these pieces into place. It is important that the shoulders of the back posts and spindles are in contact with the seat.

NOTE: The back posts (D) extend below the bottom of the seat when inserted; therefore, it is necessary to extend the back over the edge of your work table or place something under the seat to raise it up.

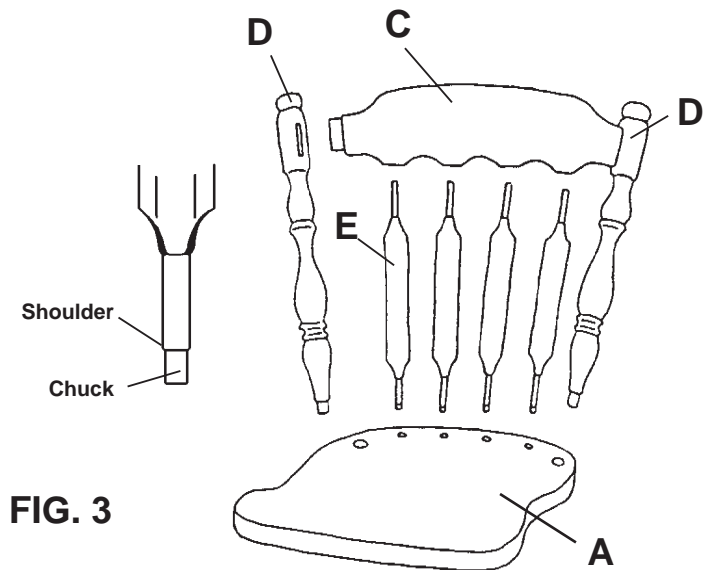

TO SECURE THE BACK:

5) Screw a #8 x 1 3/4" pan head screw (L) through the hole in each back post (D) into each end of the back (C). Rubbing a little soap on the screw threads will help them go in more easily. Tighten the screws until the back and back posts are pulled together securely. Over-tightening could strip the wood. To cover the screw hole, put a little glue around the inside of the hole on the back post (D) and insert the wooden button (N), see FIGURE 4. Carefully wipe off excess glue from around the button. Repeat for other side. (If any glue has gotten on buttons, thoroughly sand the area so that it will absorb stain or finish.)

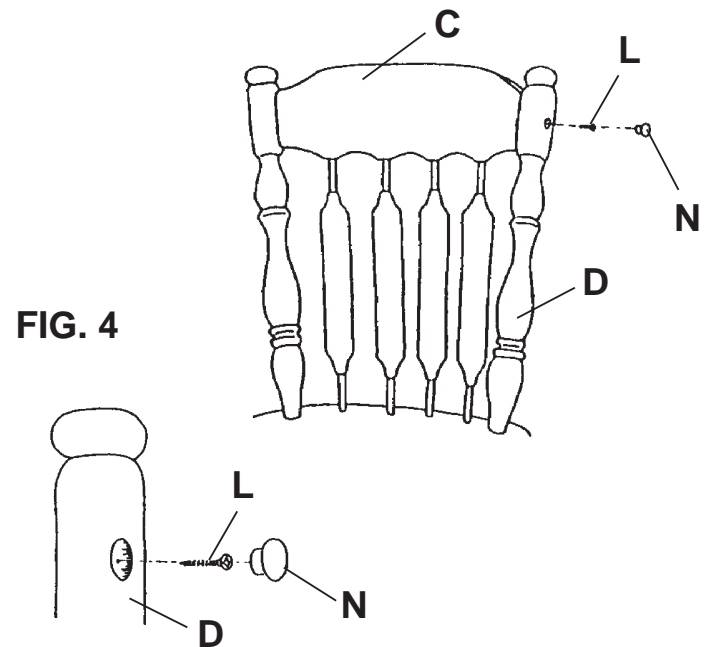

TO INSERT WEDGES

6) Turn the chair upside down, being sure to protect the top of the seat with a towel or cardboard. Put a little glue on the tapered ends of the wood wedges (M) and pound them into the slots in the bottom of the back posts (D) as shown in FIGURE 5. Be careful not to displace the back posts. Let glue dry several hours before proceeding.

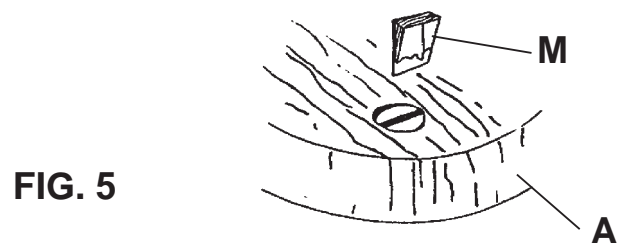

AT THIS POINT FINISH THE STOOL BEFORE PROCEEDING TO STEP 7. BE SURE TO READ THE ENCLOSED FINISHING HINTS.

TO ATTACH THE RING TO THE LEG ASSEMBLY:

- 7) Slip the brass plated ring (G) over the top of the leg assembly and down to the ring grooves on the legs, located approximately 9" above the floor. Drill a 1/8" pilot hole through the hole in the ring, approximately 5/8" into each leg. Fasten the ring into place using the #10 x 1 1/2" brass screws (J). See FIGURE 6.

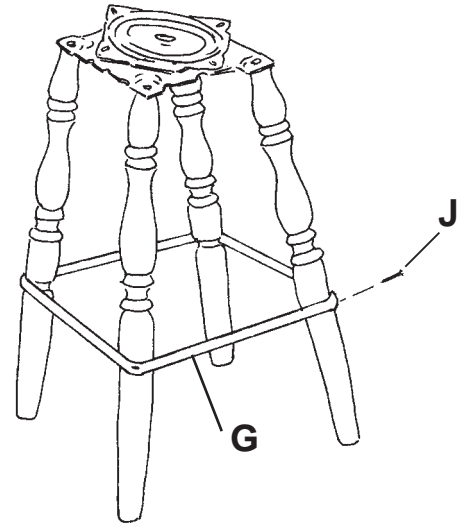

FIG. 6

TO FINISH ASSEMBLING THE COUNTERSTOOL:

- 8) Cover your work surface with a cloth or piece of cardboard to protect the finished seat. Place the seat upside down on the work surface. Be sure the front of the swivel is placed toward the front of the seat ("FRONT" is stamped on top of swivel). Place the leg assembly upside down on the bottom of the seat and line up the holes in the swivel with the pilot holes in the seat. Screw the swivel into place with the #12 x 1" pan head screws (K).

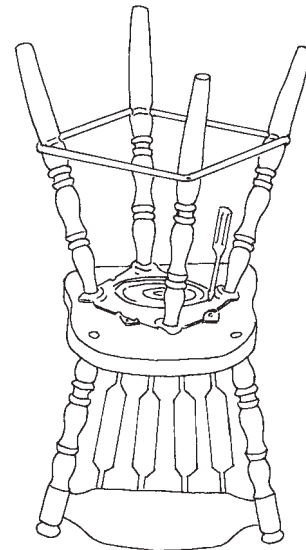

FIG. 7

