

# Shaker King Storage Bed 1426AUF

Assembly Instructions

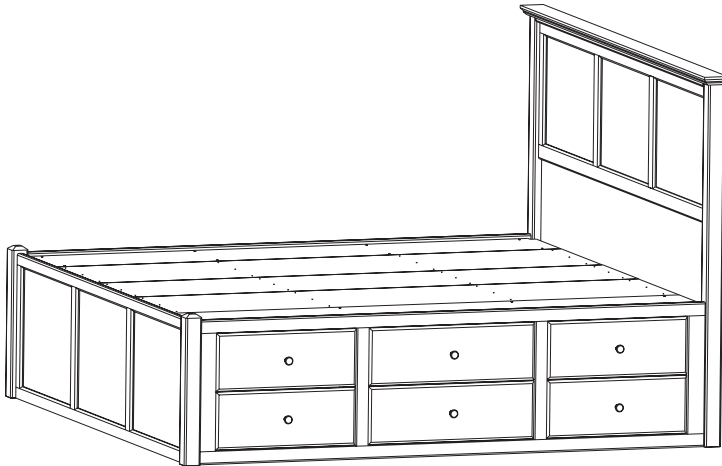

## Congratulations!

*This fine piece of furniture will make a handsome addition to your home. For the best results, start by reading the Finishing Hints **before** you begin your project.*

**For normal household use only.  
NOT recommended for commercial use.**



**Unload items from this unit prior to moving.**  
**Before loading or moving this unit, check all screws and supports for tightness.**

**DESIGN SUBJECT TO CHANGE WITHOUT NOTICE.**

**Whittier  
Wood**<sup>™</sup>  
FURNITURE

P.O. Box 2827  
Eugene, OR 97402 USA



# CALL US FIRST!

**DO NOT RETURN ITEM TO STORE**

**Service Policy:** We will replace parts which are defective, missing or damaged. Please contact Whittier Wood Products customer service department directly (by phone, fax, mail or E-mail) for replacement parts.

**Hours:** Our friendly customer service staff can be reached Monday-Friday 7:00 a.m. to 5:00 p.m. (Pacific Time). A message can be left 24 hours a day, 7 days a week.

**To Order:** Provide the complete furniture model number, part letter, production code, quantity needed, reason for replacement and your full name and address along with a telephone number in case we need to contact you.

*Parts ship from our Eugene, Oregon factory within 1 or 2 business days from the time we receive the request. Please allow 5-10 business days for delivery.*

## 800-653-3336

Outside U.S. or Canada: 541- 687- 0213

Fax: 541-687-2060 • [www.whittierwood.com](http://www.whittierwood.com)

Mail: P.O. Box 2827 • Eugene, Oregon 97402, U.S.A

## IMPORTANT NOTES:

- Read the Finishing Hints completely before beginning.
- Store the item: 1) in the box; 2) in a dry place; 3) in temperatures ranging from 40° to 90°. (Not on a cold, possibly damp, cement floor.)
- Inspect your furniture periodically for any loose glue joints or screws, or any other problem which may be affecting the stability of your furniture. Tighten or repair as needed.
- This Assembly requires two people.

Production Code:

VN

Rev. 01/08

# Shaker King Storage Bed — Parts List

If you should need to replace a part please refer to the following list for part number.

## 1427AUF (x1)

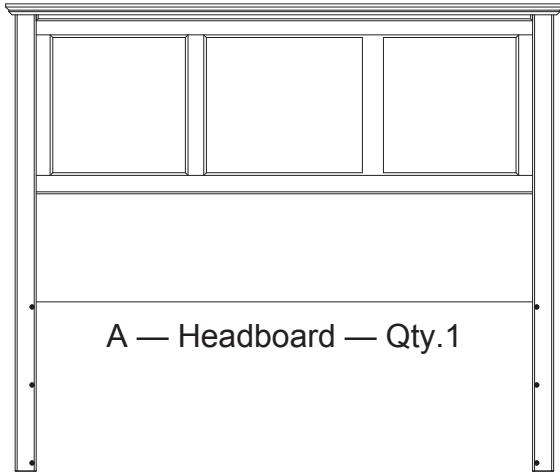

A — Headboard — Qty.1

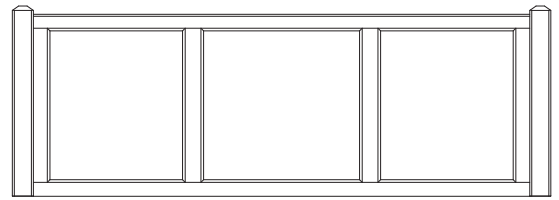

B — Footboard — Qty.1



R — Center Deckboard — Qty.1

D — Insert Nuts — Qty.12  
(Pre-Inserted)



C — Trestle — Qty.4



H — Washer — Qty. 20

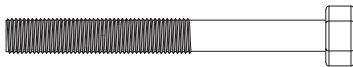

F — 1/4\"x 3\" Hex Bolt  
— Qty. 12



G — 1/4\"x 1-1/2\" Hex Bolt  
— Qty. 8



E — #8 x 1\" Black Screw — Qty. 36

## 1418AUF (x2)

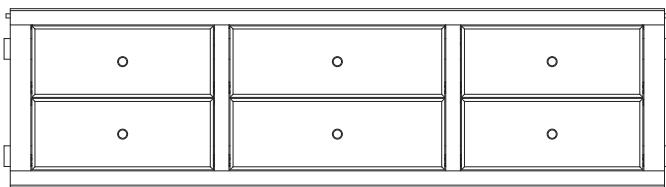

I — Pedestal Kit — Qty.1



J — Drawer Box Small — Qty.4

K — Drawer Box Large — Qty.2



P — Deckboard — Qty.1



L — Drawer Face Small — Qty.4

M — Drawer Face Large — Qty.2



N — #8 x 1-1/2\" Machine Screw  
— Qty. 6



O — Knob — Qty. 6

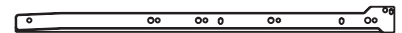

Q — Drawer Slides — Qty.12  
(Pre-Installed)

# Shaker King Storage Bed Assembly Instructions

This Assembly Requires Two People

## TOOLS REQUIRED:

Phillips screwdriver, 7/16" open end or box end wrench and tape measure.

---

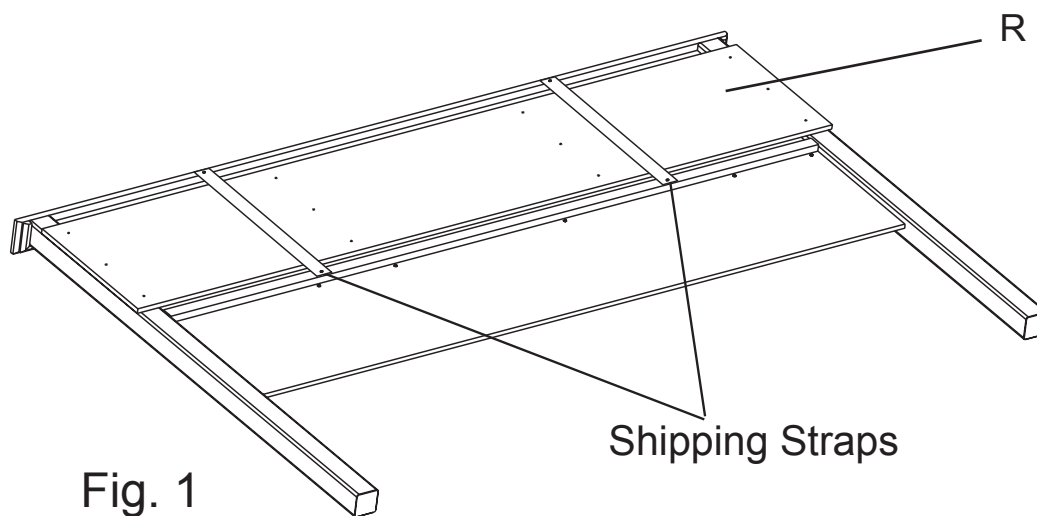

1. Remove the Trestles and Center Deckboard (R) from the back of the Headboard as seen in Fig. 1 and place them off to the side.
- 

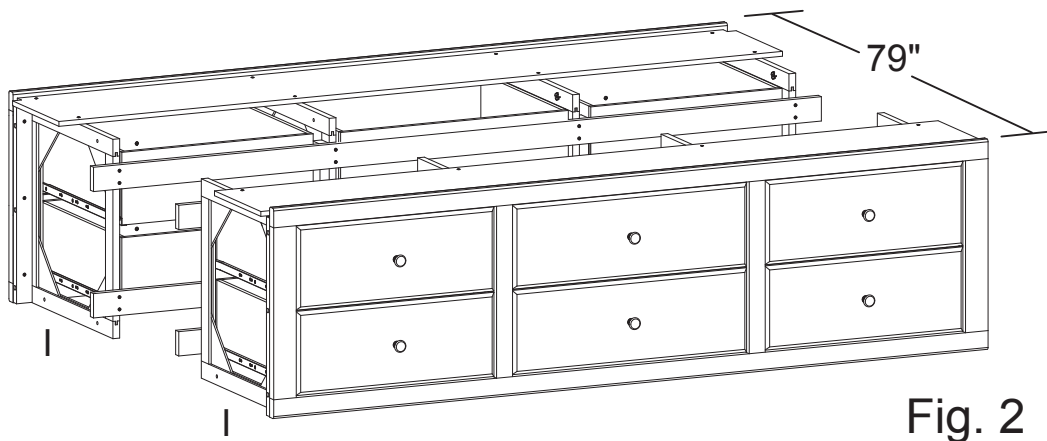

2. Place both Pedestals (I) approximately 79" apart as shown in Fig.2.

3. Remove all Drawers from both Pedestals. The drawers have been pre-aligned from the factory. Take note of where each drawer came from to insure easy re-installation. The drawers are marked on the back end to assist in this process.

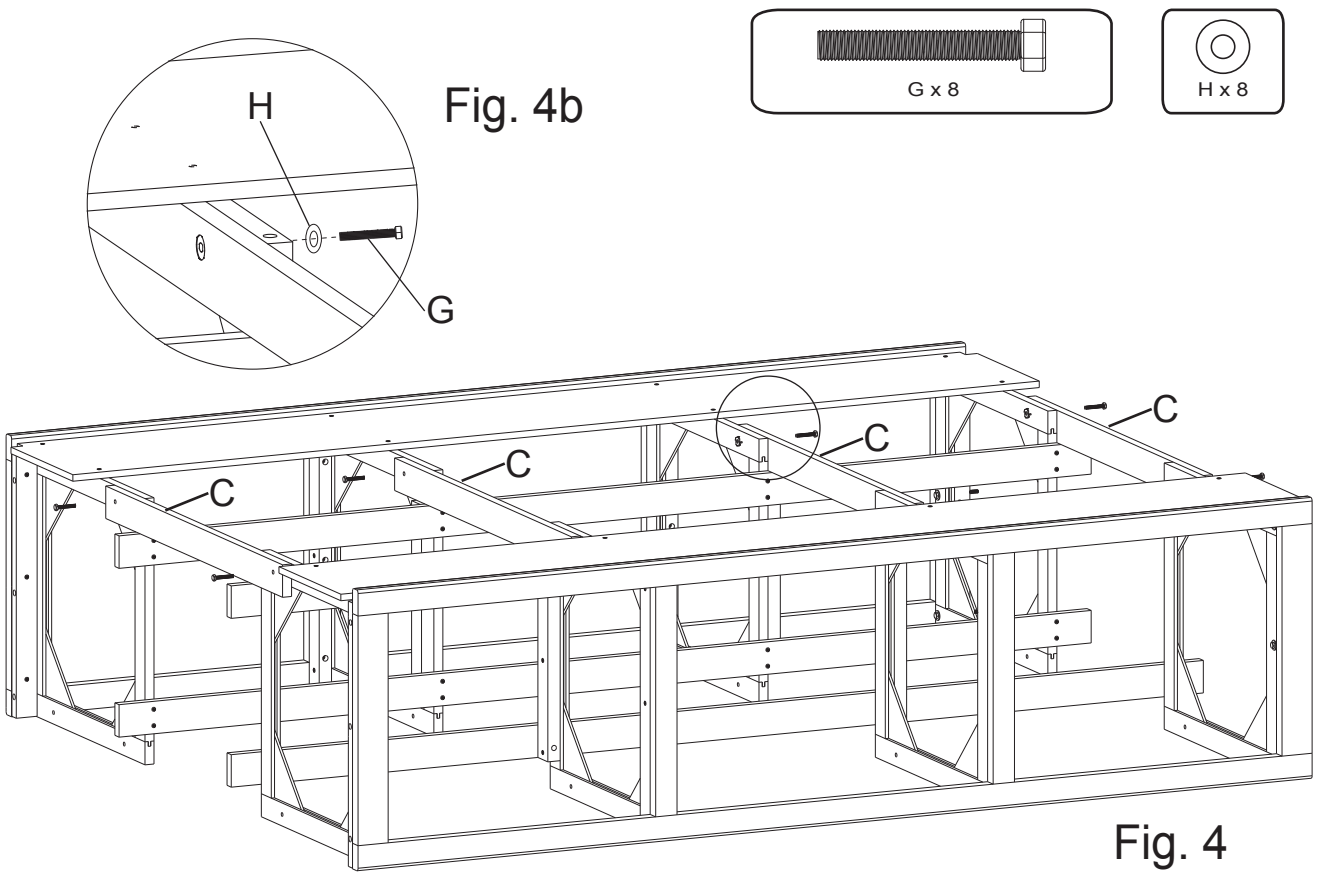

4. Place 4 Trestles (C) in between Pedestals and insert 1-1/4" Hex Bolt (G) and washer (H) as shown in Fig. 4b. Finger tighten only.

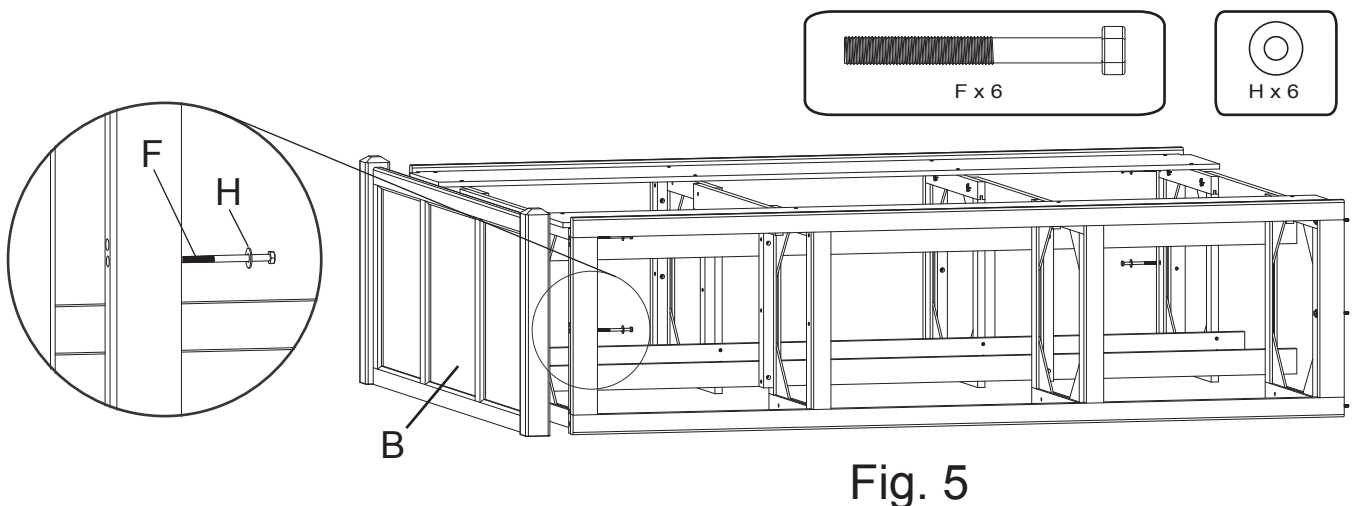

5. Assemble the Footboard (B) to the Pedestal Assembly as shown in Fig. 5. using 1/4" x 3" Hex Bolt (F) and Washer (H).

6. Repeat step 5 to assemble the Headboard (A) to the Pedestal Assembly as shown in Fig. 6.

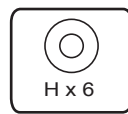
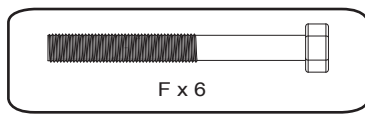
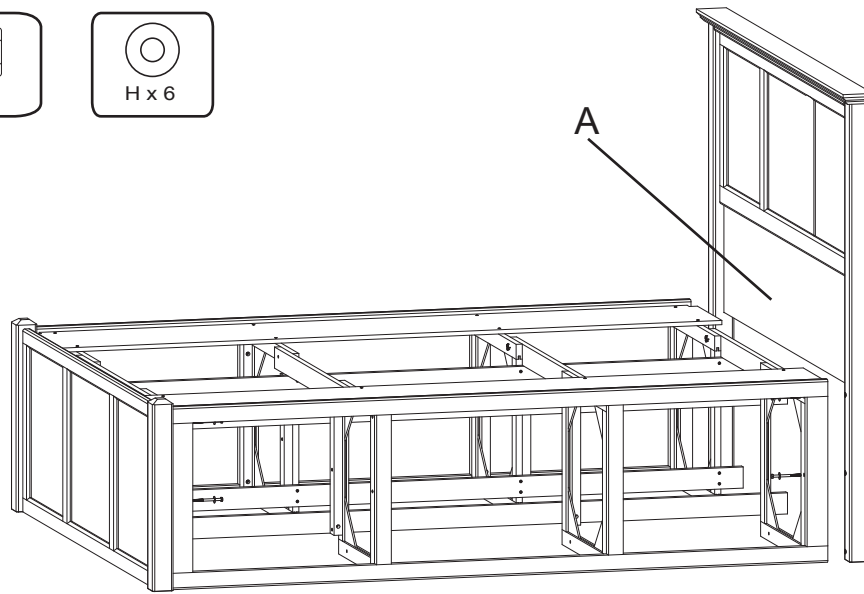

Fig.6



7. Tighten all bolts on Trestles securely.

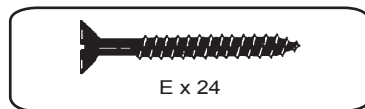
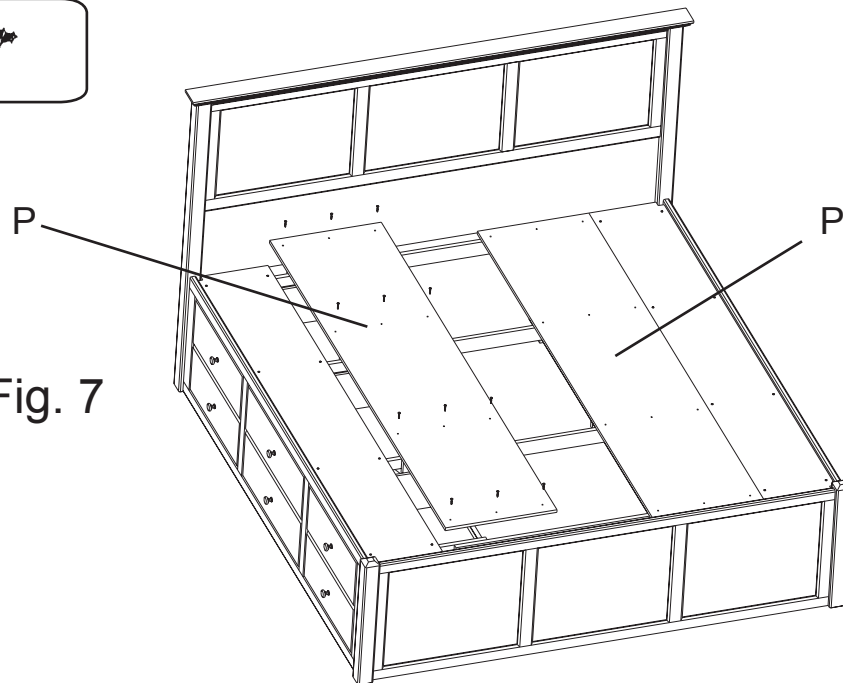

Fig. 7



8. Place Deckboards (P) as shown in Fig. 7 and secure with #8 x 1" Screw (E).

9. Place Center Deckboard (R) as shown in Fig. 9 and secure with #8 x 1" Screw (E).

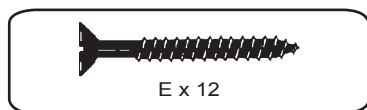
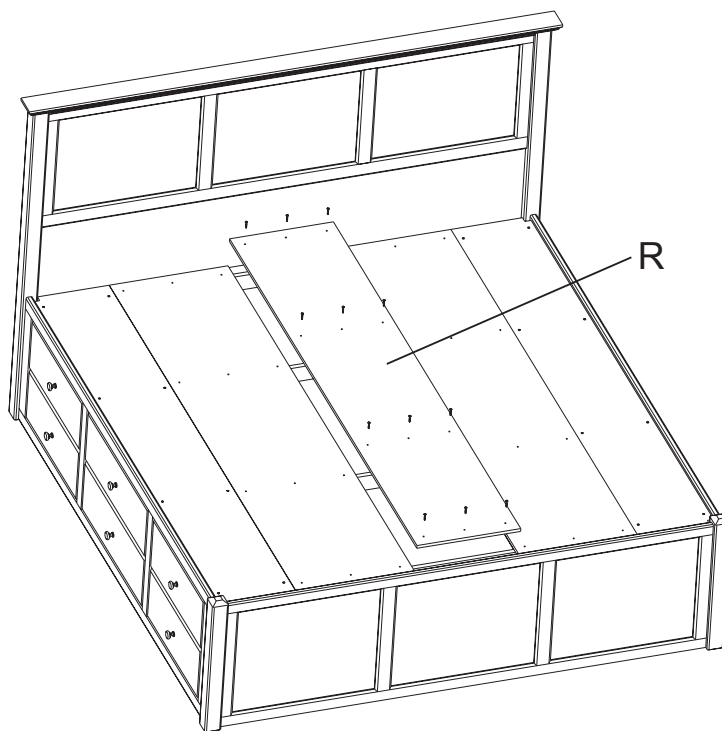

Fig. 9



---

10. Re-install Drawers into their original positions. Sleep well, and enjoy!

# Finishing Hints

## Choosing the Finish:

1. Choose a finish that will meet your expectations for the product you are finishing. Are you matching existing furniture or do you want a "natural" finish? Is the piece to be functional, decorative or both? The answers to these questions may affect the type of finish you choose.
2. Use products of the same brand to ensure compatibility of products.
3. **ALWAYS** follow the stain manufacturer's instructions. Alder is a porous hardwood and often looks best when following the finishing directions for softwoods
4. We recommend using a wood conditioner under oil base stains.
5. Work in a well ventilated and well lit area.

## Getting Started

1. **Assembly Instructions may contain special finishing information for that item.** Read both the Assembly Instructions and these Finishing Hints completely before beginning.
2. Sand the entire piece, using #220 grit sandpaper. Sand with the grain of the wood on flat surfaces and opposite the grain on turnings. Some parts are plywood. Be careful not to sand through the veneer. End grain (table top ends, seat edges, grooves on turnings, etc.) accepts more stain. Extra sanding in these areas with a #320 grit sandpaper will reduce stain absorption, creating a more evenly stained piece.
3. When sanding is completed, wipe the surface of your furniture with a cloth or tack rag. Make sure the item is free of dust before proceeding.

## Staining

1. Read and follow label directions. Stir stain well before starting.
2. Test stain on an inconspicuous spot on your project, or use the sample chip if one is provided. The sample chip must be sanded in the same way as your furniture kit to ensure the piece will accept the stain similarly. Put at least one coat of your top coat over the stain sample, as it also affects the look of the stain. **Test every type of wood that is in your kit.** Some of our products include more than one type of wood, which may react differently to the stain color. Sample chips for the different woods may be included. It may be necessary to add a second coat of stain to lighter woods to match the darker woods in your kit.

## Basic Equipment:

- |  |   |  |
|--|---|--|
| <input type="checkbox"/> Rubber gloves | <input type="checkbox"/> Tack cloth                       | <input type="checkbox"/> #220 & #320 sandpaper |
| <input type="checkbox"/> Rags          | <input type="checkbox"/> Drop cloth                       | <input type="checkbox"/> Mineral spirits       |
| <input type="checkbox"/> Paper towels  | <input type="checkbox"/> Paint brushes (bristle and foam) | <input type="checkbox"/> Masking Tape          |
| <input type="checkbox"/> Q-tips        |   |  |

3. Apply stain with a poly brush or lint-free cloth. Apply stain over a small area and wipe off excess. Working in small areas will make the color easier to control.
4. Q-tips are ideal for hard to reach areas.
5. Allow to dry thoroughly before proceeding.

## Applying the Top Coat:

**No top coat is required if using paint.**

1. **Always read and follow all label directions.** Stir your finish coat gently, **do not shake.** It will create bubbles that are hard to remove.
2. **All surfaces** (including the underside of table tops and inside drawers) **must be sealed with at least one layer of a top coat.** This will help minimize wood swelling, shrinkage, warping and cupping due to changes in moisture content or temperature.
3. We recommend that you **apply a minimum of two coats when using polyurethane or varnish (especially on all table top and work surfaces).** Sand lightly between coats using a #320 grit sandpaper or 00 steel wool for the smoothest possible finish.
4. Some water-based finishes tend to raise the grain slightly. This can be easily controlled with this sanding step. However, do not use steel wool when using water-based finishes. Strands of steel fiber caught in the wood can cause rust spots when coated with any water-based product.

## Painting:

1. For best results when painting, first coat the wood with a primer. An oil based primer would be best for a smooth finish. If you do not wish to use a solvent based primer, a water based primer would work almost as well.
2. Buy a quality brand paint. You may use a satin, semi-gloss, or gloss sheen. Apply a second coat for a smooth finish. Lightly sand between coats using a #320 grit sandpaper, so that the second coat will bond well. Repeat as desired.
3. Since there is such a variation between paint manufacturers, refer to your paint supplier for specific advice on using the paint that you purchase.