

Model #

1321AUF McKenzie Harmony Queen Storage Bed

Model #

1330AUF McKenzie Harmony King Storage Bed

Assembly Instructions

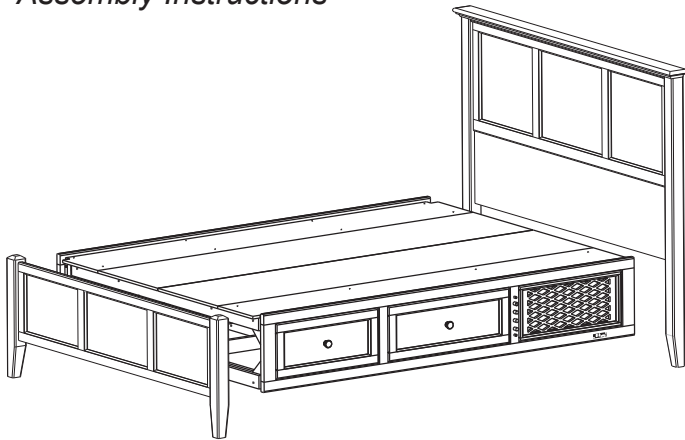

1321AUF shown

Congratulations!

This fine piece of furniture will make a handsome addition to your home. For the best results, start by reading the Assembly Instructions and Finishing Hints before you begin your project.

**For normal household use only.
NOT recommended for commercial use.**



**Unload items from this unit prior to moving.
Before loading or moving this unit, check all screws
and supports for tightness.**

Do not overload the drawers.

Keep children away from electrical components.

DESIGN SUBJECT TO CHANGE WITHOUT NOTICE.



P.O. Box 2827
Eugene, OR 97402 USA



CALL US FIRST!

DO NOT RETURN ITEM TO STORE

Service Policy: We will replace parts which are defective, missing or damaged. Please contact Whittier Wood Products customer service department directly (by phone, fax, mail or E-mail) for replacement parts.

Hours: Our friendly customer service staff can be reached Monday-Friday 7:00 a.m. to 5:00 p.m. (Pacific Time). A message can be left 24 hours a day, 7 days a week.

To Order: Provide the complete furniture model number, part letter, production code, quantity needed, reason for replacement and your full name and address along with a telephone number in case we need to contact you.

Parts ship from our Eugene, Oregon factory within 1 or 2 business days from the time we receive the request. Please allow 5-10 business days for delivery.

800-653-3336

Outside U.S. or Canada: 541- 687- 0213

Fax: 541-687-2060 • www.whittierwood.com

Mail: P.O. Box 2827 • Eugene, Oregon 97402, U.S.A

IMPORTANT NOTES:

- Completely read the Assembly Instructions and Finishing Hints before you begin your project.
- Store the item: 1) in the box; 2) in a dry place; 3) in temperatures ranging from 40° to 90°. (Not on a cold, possibly damp, cement floor.)
- Inspect your furniture periodically for any loose glue joints or screws, or any other problem which may be affecting the stability of your furniture. Tighten or repair as needed.
- This Assembly requires two people.

Production Code:

VN

12/08

1323AUF McKenzie Queen/King Harmony Storage Bed Right Pedestal Kit — Parts List

Before beginning assembly, identify each part and make sure the quantities you received match what's on this list.
If you need to replace a part, please refer to following list for name and letter.

Z — Right Pedestal Kit Assembly — Qty.1	J — Small Drawer Box — Qty. 1 (pre-assembled)	K — Large Drawer Box — Qty. 1 (pre-assembled)
L — Small Drawer Face — Qty. 1 (pre-assembled)	M — Large Drawer Face — Qty. 1 (pre-assembled)	N — #8 x 1½" Machine Screw — Qty. 2 (inserted)
O — Knob — Qty. 2 (pre-attached)	P — Deckboard — Qty.1	Q — Drawer Slides — Qty. 2 (pre-installed sets)
RS — Small Speaker Grille — Qty. 1 (pre-attached)	AB — Wire Packet — Qty. 1 (Stereo mini-pins; Stereo mini pin with two stereo RCA jacks; Powercord for Amp; two zip ties)	CD — Amp — Qty. 1 (pre-installed)
EF — Control Panel — 1 (pre-installed)	GH — Input/headphone jack plate and screws — Qty. 1 (pre-attached)	XR — Right Speaker — Qty. 1 (pre-assembled)

1324AUF McKenzie Queen/King Harmony Storage Bed Left Pedestal Kit — Parts List

Before beginning assembly, identify each part and make sure the quantities you received match what's on this list.
If you need to replace a part, please refer to following list for name and letter.

Y — Left Pedestal Kit Assembly — Qty.1	J — Small Drawer Box — Qty. 1 (pre-assembled)	K — Large Drawer Box — Qty. 1 (pre-assembled)
L — Small Drawer Face — Qty. 1 (pre-assembled)	M — Large Drawer Face — Qty. 1 (pre-assembled)	N — #8 x 1½" Machine Screw — Qty. 2 (inserted)
O — Knob — Qty. 2 (pre-attached)	P — Deckboard — Qty.1	Q — Drawer Slides — Qty. 2 (pre-installed sets)
GH — Input/headphone jack plate and screws — Qty. 1 (pre-attached)	XL — Left Speaker — Qty. 1 (pre-assembled)	RL — Large Speaker Grille — Qty. 1 (pre-attached)

1319AUF McKenzie Queen Harmony Storage Bed Headboard/Footboard or 1327AUF McKenzie King Harmony Storage Bed Headboard/Footboard — Parts List

Before beginning assembly, identify each part and make sure the quantities you received match what's on this list.
If you need to replace a part, please refer to following list for name and letter.

A — Headboard — Qty. 1	B — Footboard — Qty. 1	C — Trestle without T-Nuts — Qty. 4
D — Trestle with T-Nuts — Qty. 8	E — #8 x 1¼" Black Screw — Qty. 32 (QUEEN) — Qty. 36 (KING)	F — ¼" x 1¾" Hex Bolt — Qty. 16
G — ¼" x 2½" Hex Bolt — Qty. 16	H — Washer — Qty. 32	T — #8 x 2" Black Screw — Qty. 6
U — Foot Assembly — Qty. 2	V — Leveler Bracket — Qty. 2 (pre-installed)	W — Adjustable Glide — Qty. 2 (pre-installed)
R — Center Deckboard — Qty. 1 (KING ONLY)		

This instruction **REPLACES** the assembly instruction that is located in the Headboard/footboard carton that is named 1316AUF McKenzie Queen Storage Bed or 1326AUF McKenzie King Storage Bed. **USE THIS ASSEMBLY INSTRUCTION INSTEAD.**

1321AUF McKenzie Harmony Queen Storage Bed 1330AUF McKenzie Harmony King Storage Bed Assembly Instructions

This Assembly Requires Two People

TOOLS REQUIRED: Phillips screwdriver, 7/16" or adjustable wrench, power drill and drill bits

1321AFUF shown for illustration purposes.

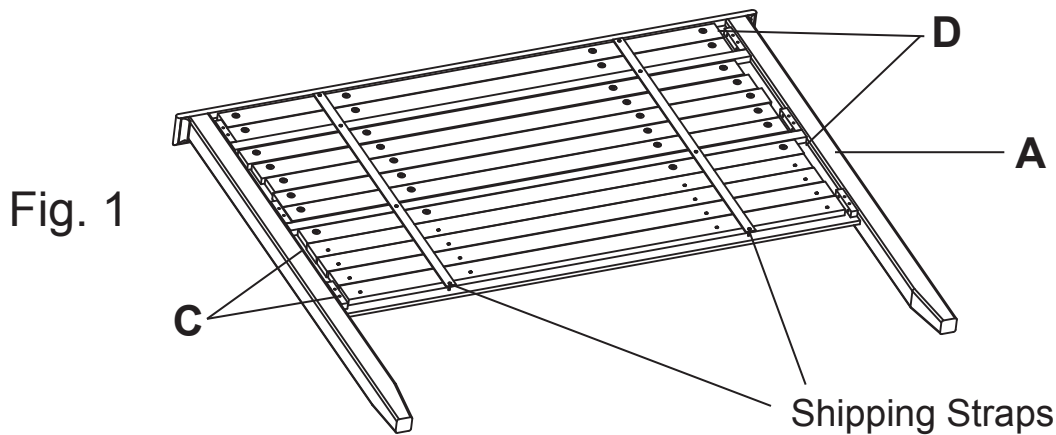

1. Remove the Trestles (C and D) from the Headboard (A) and place them off to the side. See Figure 1.

Fig. 2

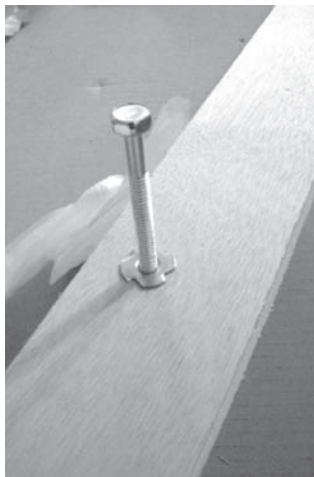
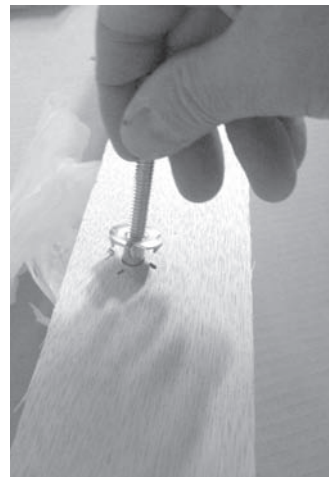
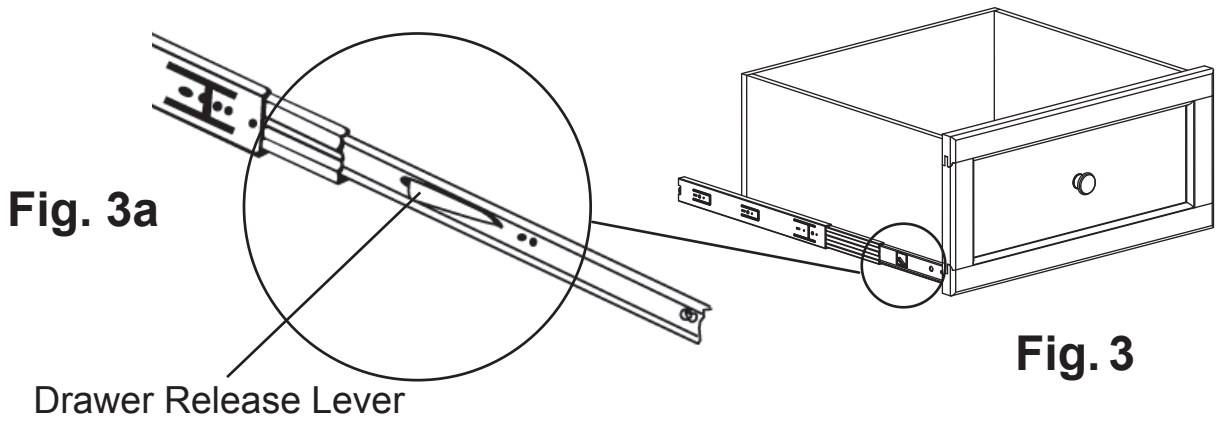

Fig. 2a



2. Remove all of the T-nuts from **ONE** of the Trestles (D). (An easy way to do that is to insert a Hex Bolt into a T-nut, wiggle the T-nut loose and pull it out of the Trestle. Remove the Hex Bolt and recycle the T-nuts.) See Figures 2 and 2a.



3. Remove Drawers (J & K) from Pedestal Kits (Z and Y). To remove drawers, push up on the left side of the Drawer Release Lever while pushing down on the right Drawer Release Lever (see Figures 3 and 3a). Note where each drawer came from to ensure correct re-installation. (Positions are marked on drawer backs.)

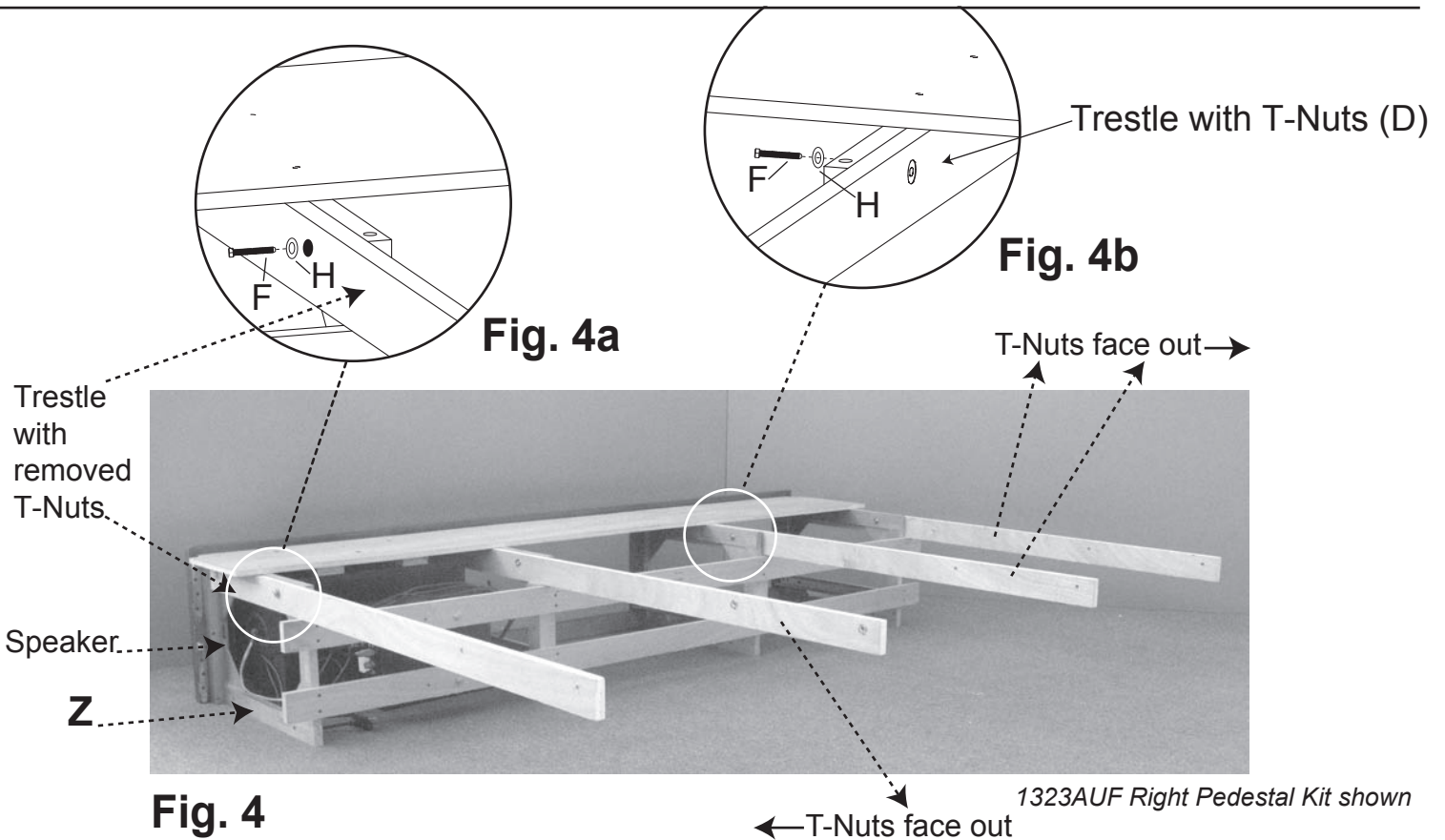

NOTE: DO NOT TIGHTEN BOLTS UNTIL YOU COMPLETE STEP TEN.

How to identify whether a part is right or left: Stand and face the headboard and look to see where the part will be used. If it fits on the left side of the headboard, it is a left kit part and vice versa.

4. Place the trestle with the removed T-Nuts on the first rib by the speaker of the Right Pedestal (Z) and run two $\frac{1}{4}$ " x $1\frac{3}{4}$ " Hex Bolts (F) and Washers (H) from the outside through the Trestle and into the T-Nuts in the rib. See Figure 4 and 4a. Install the remaining three Trestles with T-Nuts (D) with $\frac{1}{4}$ " x $1\frac{3}{4}$ " Hex Bolts (F) and Washers (H). Position these Trestles so the T-Nuts face out as shown in Steps 4 and 4b.

Fig. 5

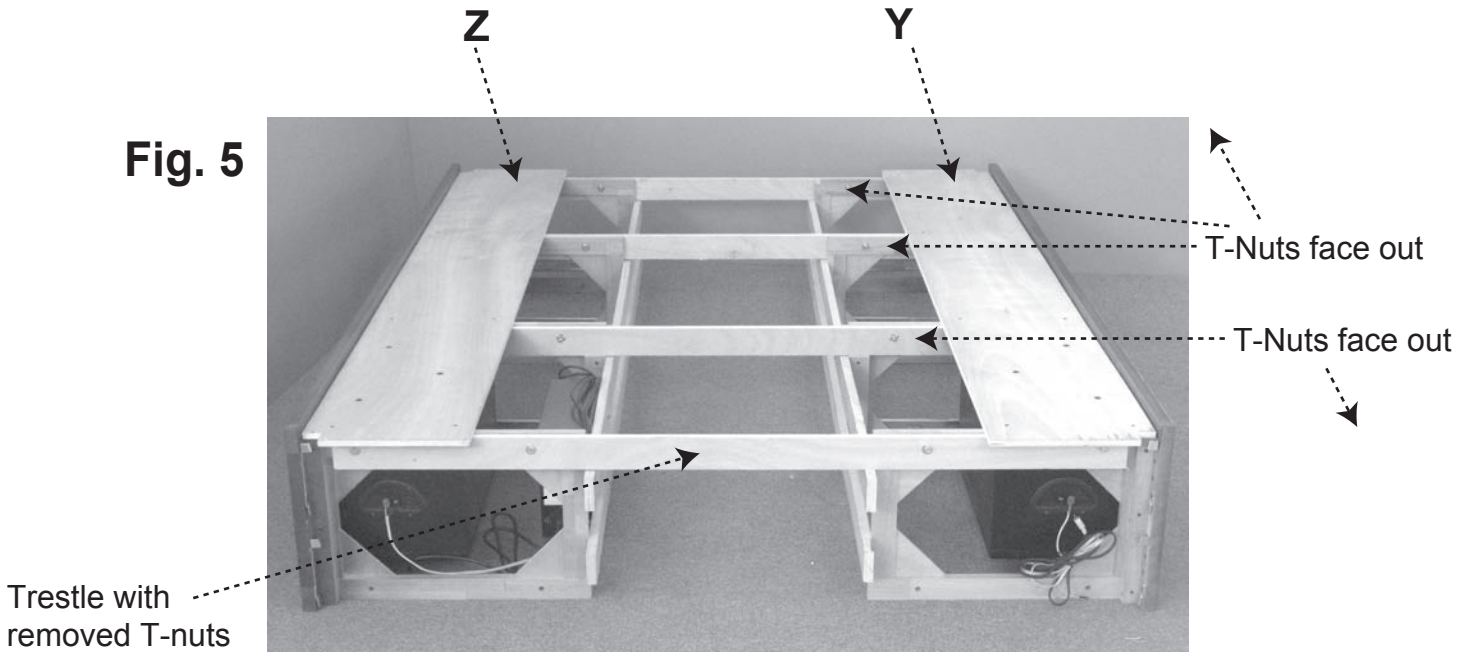

5. Position the Left Pedestal (Y) so the holes and T-nuts in the Trestles align to the holes and T-nuts in the ribs. Attach with $\frac{1}{4}$ " x $1\frac{3}{4}$ " Hex Bolts (F) and Washers (H) as in Step 4. Remember that the T-nuts face out. See Figure 5.

DO NOT TIGHTEN BOLTS UNTIL COMPLETING STEP 10.

Fig. 6

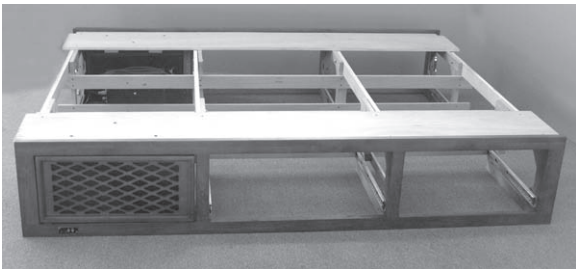
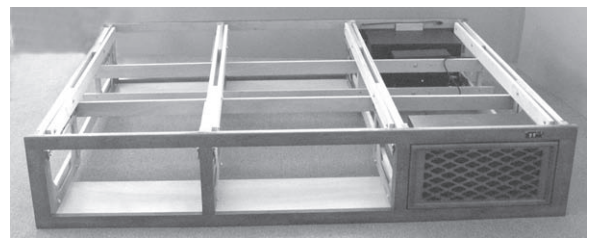

Fig. 6a



Fig. 6b



6. Rotate Pedestal Assembly upside-down so that the deckboards are on the floor. See Figures 6, 6a and 6b.

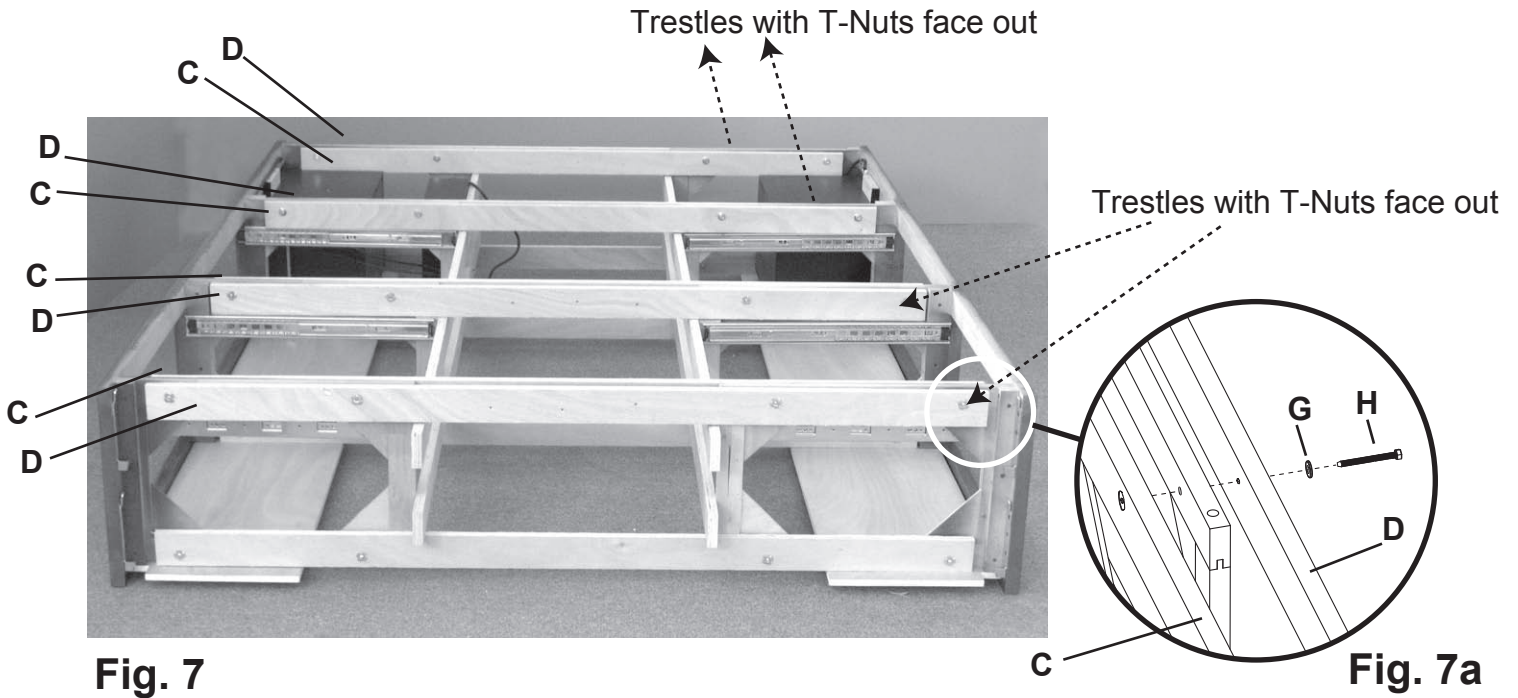

7. Place the remaining Trestles (C and D) on the Pedestal Assembly. Face the Trestles with T-Nuts (D) toward the ends of the Assembly from the center as shown in Figure 6. Insert $\frac{1}{4}$ " x $2\frac{1}{2}$ " Hex Bolt (G) and Washer (H). See Figures 7 and 7a.
DO NOT TIGHTEN BOLTS UNTIL YOU COMPLETE STEP 10.

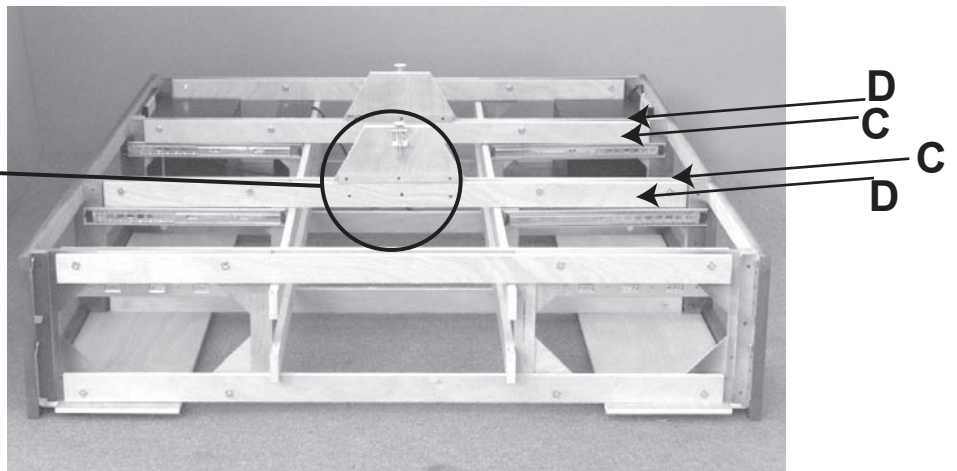
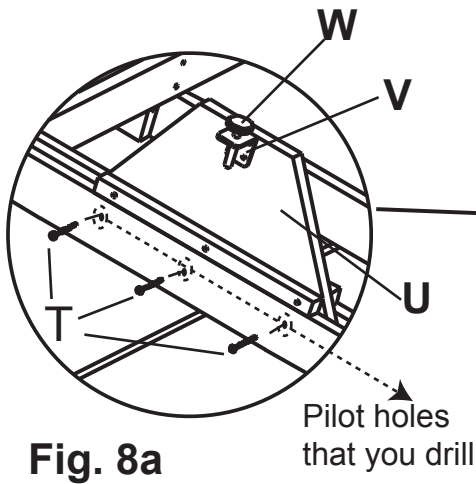

8. On each inner pair of Trestles (C and D), place a Foot Assembly (U) between the two middle trestles. Using a $\frac{3}{32}$ " or 2mm bit, drill three holes through each pair of trestles and foot assemblies as shown in Figure 8a. Attach using six #8 x 2" Black Screws (T). See Figures 8 and 8a. Untie the input jack and speaker wires that are affixed to the left pedestal and string them across the frame and to the Amp located in the Right Pedestal. **DO NOT CONNECT THE WIRES TO THE AMP YET.**
 Rotate the bed so the deckboards are face-up again.



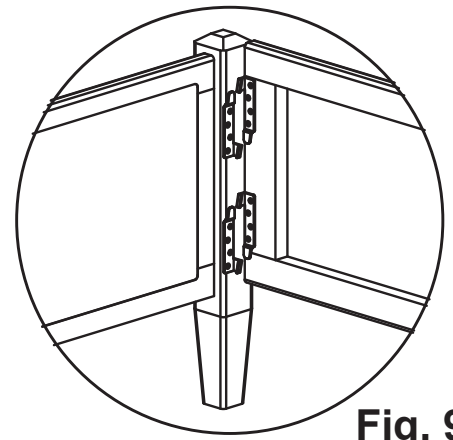
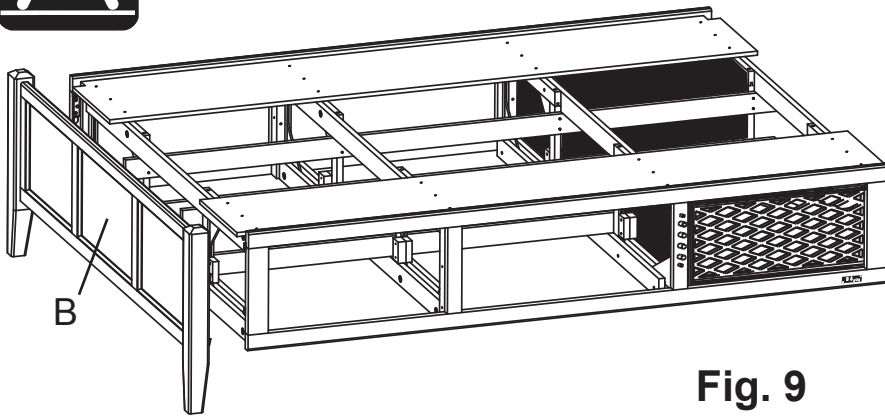

Fig. 9b

Fig. 9

9. Attach the Footboard (B) to the Pedestal Assembly. Align brackets and slide the Pedestal Assembly down on to the Footboard (B). See Figures 9 and 9b.

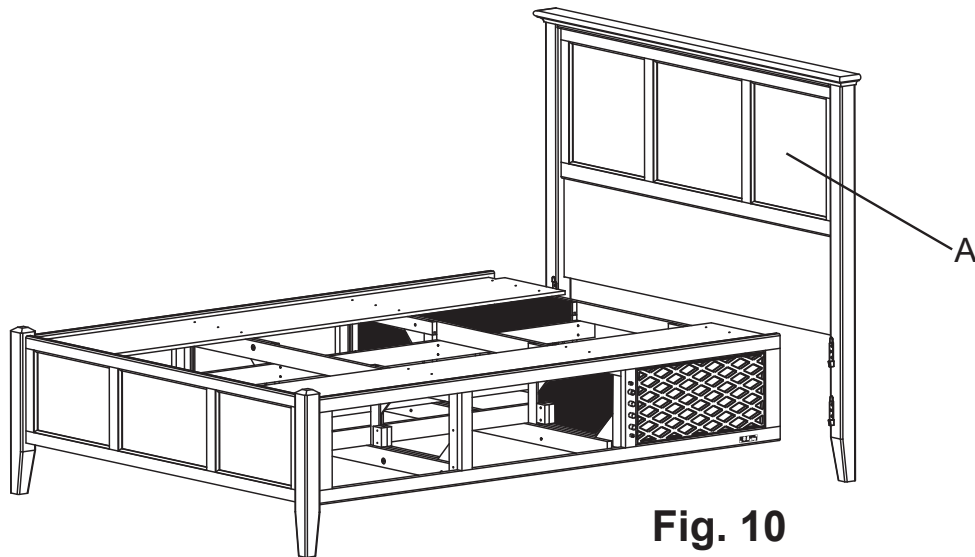

Fig. 10

10. Attach Headboard (A) to Pedestal Assembly as in previous step. See Figure 10.
NOTE: NOW TIGHTEN ALL BOLTS ON TRESTLES.

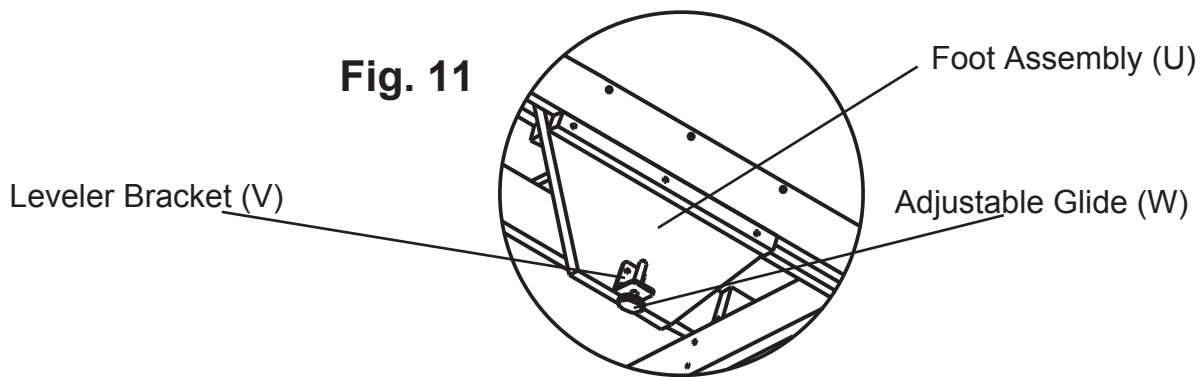
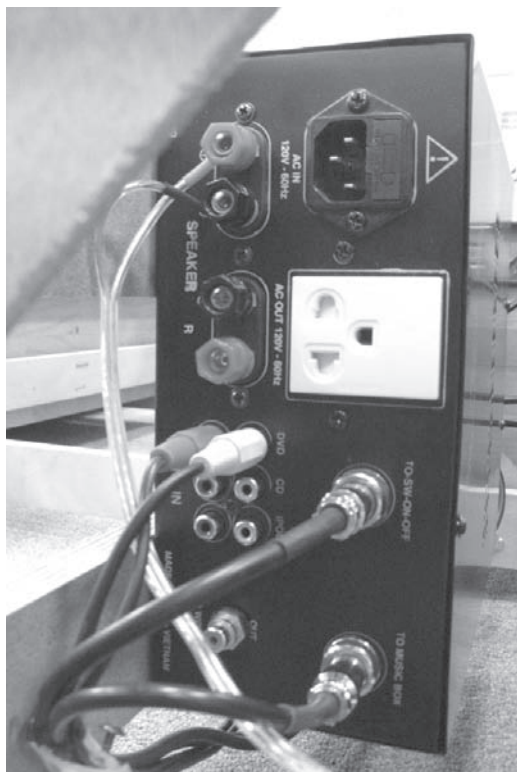

Fig. 11

11. Adjust Glides (W) on the Foot Assemblies (U) so the Glides just touch the floor. See Figure 11.

TO WIRE THE SPEAKERS:

The easiest way to reach the speakers is by standing inside the bed assembly.



Wires already installed by the factory.

TO WIRE THE LEFT SPEAKER TO THE AMP:

hole properly
exposed in
the red post

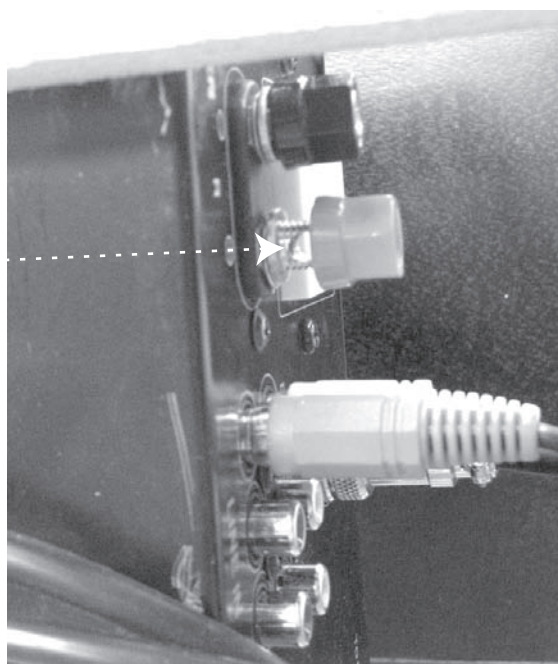

Fig. 12

12. On the amp, unscrew the red plug that does not already have a speaker wire attached until you see the hole on the post. See Figure 12. Insert the red-tipped speaker wire that is connected to the left speaker into the hole in the red post and tighten the cap until the wire end is covered. Do not over-tighten. Repeat for the black post/wire. See Figure 12.

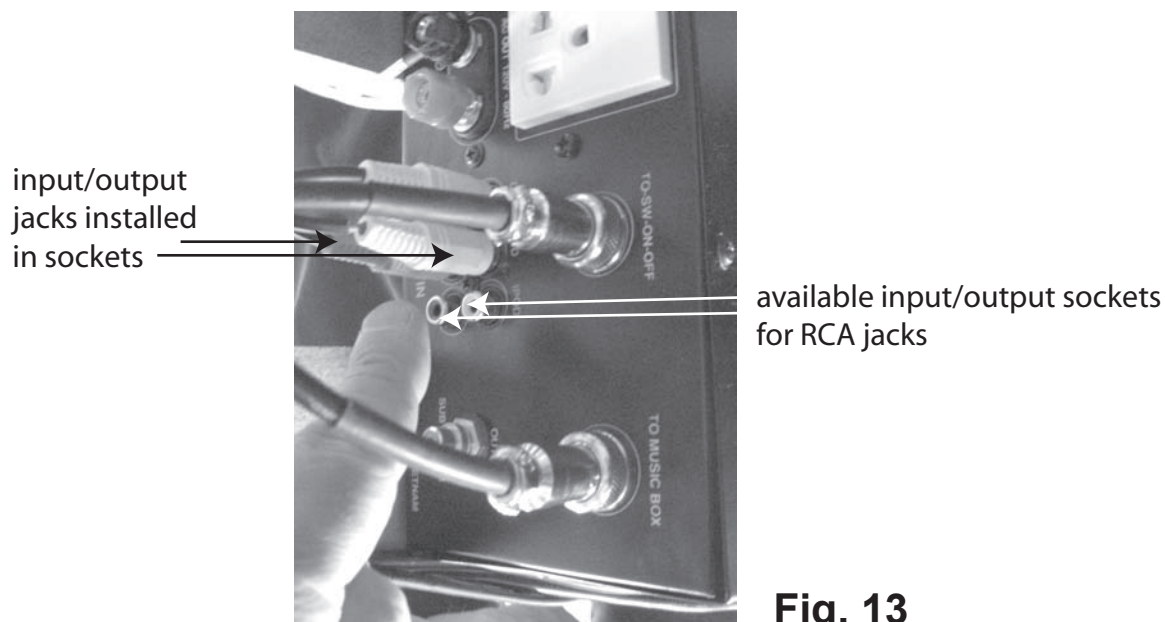

Fig. 13

- 13.** To attach the input/headphone jack from the Left Pedestal to the Amp, plug the jack set into the middle pairs of the input/output jack sockets. See Figure 13. Gather up the slack of the wires from the Left Pedestal and secure to the frame with one of the provided zip ties.

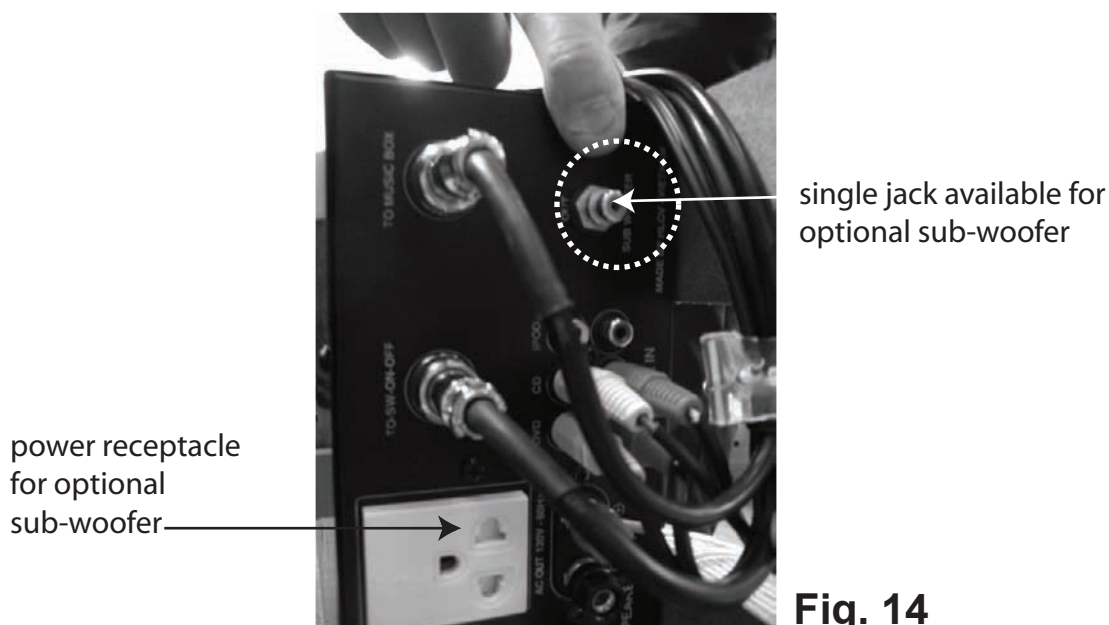

Fig. 14

- 14. OPTIONAL STEP.** The gold socket seen above is available as a connection to your sub-woofer. Plug the RCA jack from your sub-woofer into the gold socket and plug the power cord from your sub-woofer into the power receptacle. See Figure 14.

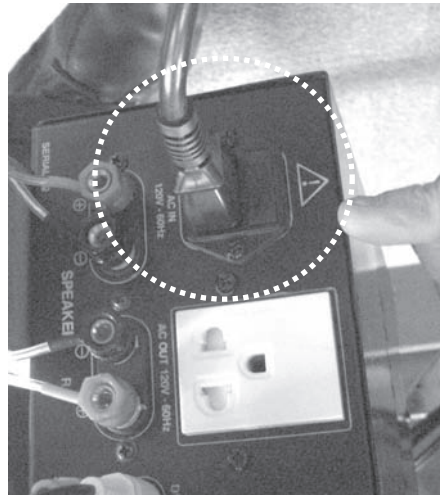

Fig. 15

15. Plug the socket end of the power cord into the recessed plug receptacle on the Amp. See Figure 15.

**Read the section on “Getting Sound Through The Bed.”
Test your devices to ensure correct assembly/connections.**

To move the control panel to the left pedestal, please call Whittier Wood Furniture Customer Service, Monday through Friday from 7:00 a.m. - 5:00 p.m. PST and one of our friendly representatives will help guide you through the process.

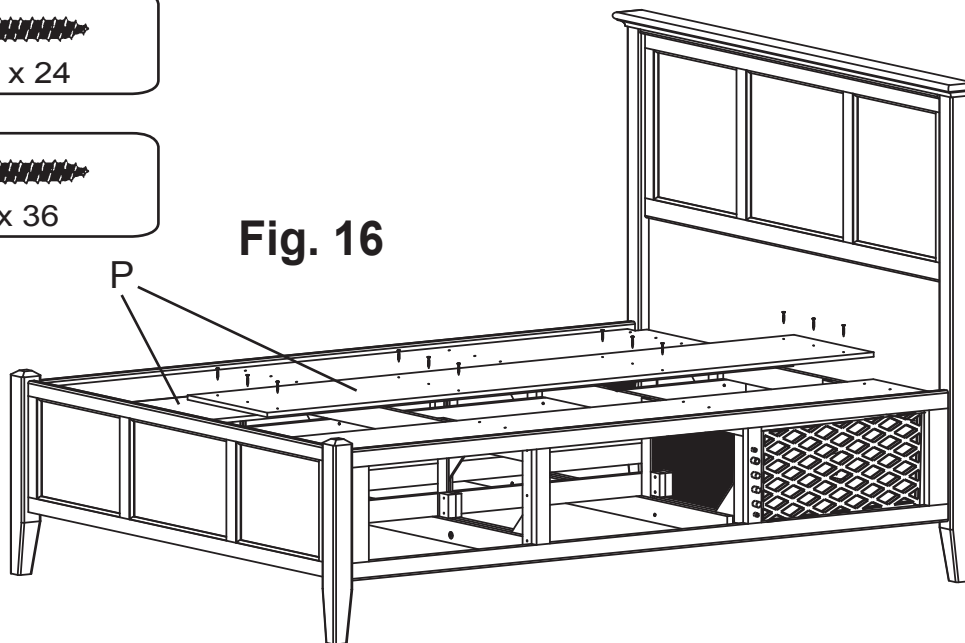
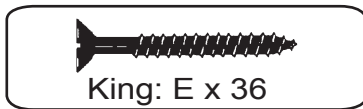

Fig. 16

16. Place Deckboards (P) as shown in Figure 16. There should be a small gap between each deckboard. FOR KING, ALSO PLACE CENTER DECKBOARD (R). Secure with #8x1¼" Black Screws (E).

17. Carefully align drawer slides into the cabinet and gently push the drawers back to their original positions. Sleep well, and enjoy your sound experience!

GETTING SOUND THROUGH THE BED:

To play music through your Harmony Bed, you need a device to input sound to the bed's amplifier. Following are two options we recommend:

1. CONNECTING HAND-HELD DEVICES:

These devices can be, but are not limited to: an iPod™, MP3 player, radio or docking station. Included in your Wire Packet (AB) are two different types of wire connections to use in the following manner:

A. To connect your device directly to the system, use the mini-pin/mini-pin cable. See Figure A. Plug one end into the headphone socket of your device. Plug the other end of the cable into the input socket on the jack plate located on either side of the bed. See Figure B. Turn on the power (green button located on the control panel) to the amplifier. The system will now play recordings from your device.



mini-pin/mini-pin cable **Fig. A**

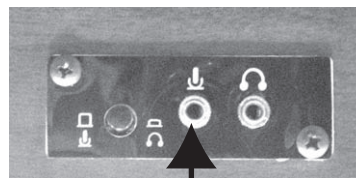

Fig. B

Input socket

B. To connect your device via a docking station, plug your docking station into a standard electrical outlet. Plug the mini-pin cable into the output socket of the docking station. Plug the other end of the cable into the input socket of the bed as shown in Figure B. Insert your playing device on to the docking station. Turn the power on to the amplifier. The system will now play recordings from your device.

2. CONNECTING STEREO OR TV COMPONENTS WITH RCA CONNECTIONS:

This option is for connecting non-portable CD or DVD players that use RCA connections.

To connect your unit to the system, use the mini-pin/RCA cable provided in the Wire Packet (AB). See Figure A. Plug the two RCA jacks into the output sockets on your device. Plug the mini-pin end of the cable into the input socket located on the side of the bed. See Figure B.

Please note that on the back of the amplifier, there is a set of RCA sockets for you to use to connect additional components. See Figure C.



mini-pin/RCA cable **Fig. A**

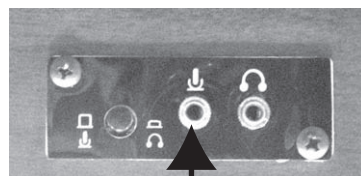
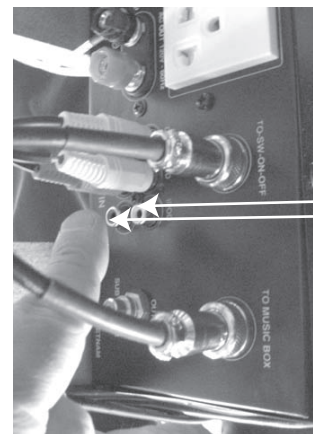

Fig. B

Input socket



available input/output sockets for an RCA jack

Fig. C

Diagram of the Jack Plates and Control Panel

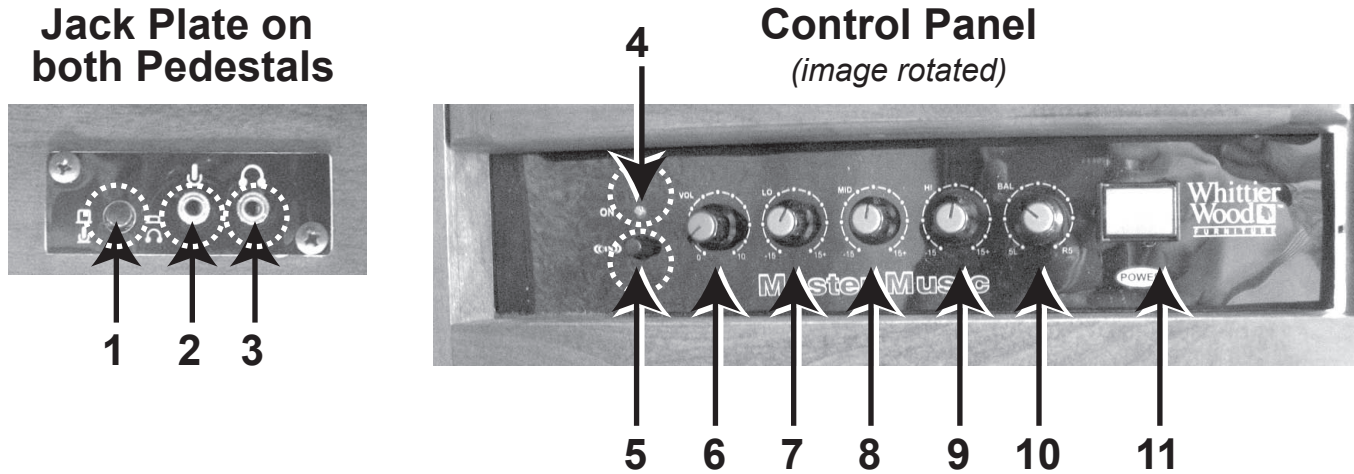

1. Amplifier by-pass

To listen through your headphones, depress this button. To listen using the amplifier, this button must be raised.

2. Input socket

To connect a device using mini-pins to the bed.

3. Output socket

Connect your headphone via this socket.

4. ON indicator

This red light is illuminated when the power is on.

5. Loudness filter sound button

6. Volume control to the speakers

7. Low-range control to the speakers

8. Mid-range control to the speakers

9. High-range control to the speakers

10. Balance control to the speakers

11. Power button

Depress this green button to get power to the system.

Finishing Hints

Choosing the Finish:

1. Choose a finish that will meet your expectations for the product you are finishing. Are you matching existing furniture or do you want a "natural" finish? Is the piece to be functional, decorative or both? The answers to these questions may affect the type of finish you choose.
2. Use products of the same brand to ensure compatibility of products.
3. **ALWAYS** follow the stain manufacturer's instructions. Alder is a porous hardwood and often looks best when following the finishing directions for softwoods
4. We recommend using a wood conditioner under oil base stains.
5. Work in a well ventilated and well lit area.

Getting Started

1. **Assembly Instructions may contain special finishing information for that item.** Read both the Assembly Instructions and these Finishing Hints completely before beginning.
2. Sand the entire piece, using #220 grit sandpaper. Sand with the grain of the wood on flat surfaces and opposite the grain on turnings. Some parts are plywood. Be careful not to sand through the veneer. End grain (table top ends, seat edges, grooves on turnings, etc.) accepts more stain. Extra sanding in these areas with a #320 grit sandpaper will reduce stain absorption, creating a more evenly stained piece.
3. When sanding is completed, wipe the surface of your furniture with a cloth or tack rag. Make sure the item is free of dust before proceeding.

Staining

1. Read and follow label directions. Stir stain well before starting.
2. Test stain on an inconspicuous spot on your project, or use the sample chip if one is provided. The sample chip must be sanded in the same way as your furniture kit to ensure the piece will accept the stain similarly. Put at least one coat of your top coat over the stain sample, as it also affects the look of the stain. **Test every type of wood that is in your kit.** Some of our products include more than one type of wood, which may react differently to the stain color. Sample chips for the different woods may be included. It may be necessary to add a second coat of stain to lighter woods to match the darker woods in your kit.

Basic Equipment:

- | | | |
|--|---|--|
| <input type="checkbox"/> Rubber gloves | <input type="checkbox"/> Tack cloth | <input type="checkbox"/> #220 & #320 sandpaper |
| <input type="checkbox"/> Rags | <input type="checkbox"/> Drop cloth | <input type="checkbox"/> Mineral spirits |
| <input type="checkbox"/> Paper towels | <input type="checkbox"/> Paint brushes (bristle and foam) | <input type="checkbox"/> Masking Tape |
| <input type="checkbox"/> Q-tips | | |

3. Apply stain with a poly brush or lint-free cloth. Apply stain over a small area and wipe off excess. Working in small areas will make the color easier to control.
4. Q-tips are ideal for hard to reach areas.
5. Allow to dry thoroughly before proceeding.

Applying the Top Coat:

No top coat is required if using paint.

1. **Always read and follow all label directions.** Stir your finish coat gently, **do not shake.** It will create bubbles that are hard to remove.
2. **All surfaces** (including the underside of table tops and inside drawers) **must be sealed with at least one layer of a top coat.** This will help minimize wood swelling, shrinkage, warping and cupping due to changes in moisture content or temperature.
3. We recommend that you **apply a minimum of two coats when using polyurethane or varnish (especially on all table top and work surfaces).** Sand lightly between coats using a #320 grit sandpaper or 00 steel wool for the smoothest possible finish.
4. Some water-based finishes tend to raise the grain slightly. This can be easily controlled with this sanding step. However, do not use steel wool when using water-based finishes. Strands of steel fiber caught in the wood can cause rust spots when coated with any water-based product.

Painting:

1. For best results when painting, first coat the wood with a primer. An oil based primer would be best for a smooth finish. If you do not wish to use a solvent based primer, a water based primer would work almost as well.
2. Buy a quality brand paint. You may use a satin, semi-gloss, or gloss sheen. Apply a second coat for a smooth finish. Lightly sand between coats using a #320 grit sandpaper, so that the second coat will bond well. Repeat as desired.
3. Since there is such a variation between paint manufacturers, refer to your paint supplier for specific advice on using the paint that you purchase.



McKenzie Harmony Storage Bed

All electrical components listed below are eligible for service for up to one year after date of purchase. Whittier will offer service, repair or replacement of electrical components after return and review of the unit(s).

The Registration Card (below) and a copy of the sales receipt must be completed to validate date of purchase. Consumer must contact Whittier Wood Furniture customer service for return authorization to Eugene, Oregon for service, repair or replacement. Service or replacements after the one year period will be assessed and charged at a reasonable rate.

Electrical Components List

- AB — Wire Packet — Qty. 1
- CD — Amp — Qty. 1
- EF — Control Panel — Qty. 1
- XR — Right Speaker — Qty. 1
- XL — Left Speaker — Qty. 1



3787 West 1st Avenue • P.O. Box 2827 • Eugene, Oregon • USA 97402 • www.whittierwood.com • 800-653-3336 • (541) 687-0213 • Fax (541) 687-2060

McKenzie Harmony Storage Bed Registration Card

YOU MUST ATTACH A COPY OF PROOF OF PURCHASE/RECEIPT

Name: _____

Address: _____

Day Phone: (____) _____ Evening Phone: (____) _____

Email Address: _____ Date of Purchase: _____

Model # _____ Production Code (found lower right corner of Instructions): _____

Retailer Name and Address: _____



3787 West 1st Avenue • P.O. Box 2827 • Eugene, Oregon • USA 97402 • www.whittierwood.com • 800-653-3336 • (541) 687-0213 • Fax (541) 687-2060